

**871PH Series**  
**pH and ORP Sensors and Accessories**



The Foxboro® brand 871PH Series are rebuildable, precision, electrochemical sensors, and when used in conjunction with 871PH accessories, are suitable for pH and ORP measurement applications.

**INTRODUCTION**

The 871PH Series sensors are used with Foxboro 870ITPH Intelligent Transmitters, 875PH Intelligent Analyzers, 870PH Analog Transmitters, and 873PH and 873DPX Electrochemical Analyzers. The Model 871PH Sensor includes a robust and continuously reusable sensor body with a field replaceable measuring electrode, and field replaceable reference junction and electrolyte. Numerous options and accessories are offered to enhance the performance of these transmitters.

**FEATURE HIGHLIGHTS**

- ▶ Unique pH glass - exceptionally stable, remains fast and accurate after severe temperature cycling (121°C/250°F).
- ▶ Proven high stability, high accuracy, and long life.
- ▶ Easy-to-use body design simplifies installation, calibration, maintenance, and replacement.
- ▶ More reliable measurements permit tighter process control.
- ▶ Longer life plus easy mounting reduces maintenance costs.

## GENERAL DESCRIPTION

Measurement of pH by these sensors is accomplished by immersing a glass or metal electrode, with a reference electrode, into a process solution. The glass or metal electrode produces an electrical potential proportional to the logarithm of the hydrogen ion activity. The reference electrode completes the circuit and provides a stable reference for the glass or metal electrode. These two electrodes constitute an electrolytic cell having a millivolt output that is proportional to the pH of the solution.

ORP is related to the logarithm of the ratio of oxidation activity to reduction activity, just as pH is related to the logarithm of the hydrogen ion activity. A solution that contains an excess of oxidizing agent has a positive ORP while one containing an excess of reducing agent has a negative ORP.

Typical ORP applications include treatment of chromate and cyanide wastes produced by plating, chemical, and metal treatment plants. ORP monitoring enables industry to determine reaction end points and to meet today's stringent environmental requirements.

## ENHANCED MODEL 871PH DESIGN

Many new measuring electrodes, reference junctions, options, and accessories have been added to the 871PH sensor family. These include:

- ▶ High temperature electrode featuring unique DolpHin™ Series high temperature glass.
- ▶ Patented double junction reference with integral Nafion ion barrier.
- ▶ Variopin Quick cable connector.
- ▶ Optional selections for high temperature cable and O-ring material.
- ▶ A ptfе collar, which improves self-cleaning, and also minimizes coating buildup.

## SINGLE MULTI-PURPOSE ASSEMBLY

This multi-purpose sensor assembly is suitable for most process pH and ORP measurement applications. Its flexibility is further enhanced when used with a variety of mounting accessories. The sensor accepts a variety of glass pH, metallic pH, and ORP electrodes. The unit is not affected by normally encountered chemical solutions and is capable of withstanding continuous operation in a wide range of process pressures and temperatures.

## CHOICE OF SENSOR BODY

The sensor assembly is available in either a Ryton or CPVC body. The Ryton body can be used in most normally encountered chemical solutions, and is the preferred material where organic chemicals are present. The CPVC body is used in applications involving hypochlorites or peroxides (e.g., bleach).

## CHOICE OF MEASURING ELECTRODE AND BODY MATERIAL

Each measuring electrode is available in either a Ryton body or ptfе body. Ryton measuring electrode body should be used when using a Ryton sensor body. The ptfе electrode body is used with a CPVC sensor body.

Glass pH electrodes offer the best performance in most solutions and inherently provide the most accurate measurement. The glass electrode is available in one of three types: spherical, flat, and domed. Antimony, platinum, and gold electrodes are also offered for specific applications. See below for description and recommended use for each type.

### Spherical Glass Electrode

The spherical glass electrode is the default choice for standard process applications where the range is 0 to 14 pH, and the temperature is routinely less than 100°C (212°F). This electrode features a glass formulation with minimal sodium ion error.

### Flat Ruggedized Glass Electrode

The flat ruggedized glass electrode is recommended for process applications where the process water contains solid materials because of its very durable abrasion- and corrosion-resistant construction. The electrode is particularly resistant to wear, stress, and abuse caused by physical operating conditions. Its optimum accuracy is in the range of 2 to 12 pH, and the temperature is routinely less than 85°C (185°F).

### Domed Glass Electrode

The domed glass electrode is made with DolpHin pH sensor glass formulation. It is recommended for the harshest process application. This DolpHin pH glass sensor is suitable for applications with:

- ▶ High temperature, up to 121°C (250°F)
- ▶ Temperature cycling
- ▶ Extremes of chemical concentrations.

This electrode provides extremely fast pH response, and it lasts longer than other glass formulations in the harshest applications.

### Antimony Electrode

Metallic (antimony) pH electrodes are available for solutions containing hydrofluoric acid or other chemicals which attack glass. Optimal pH range is 3 to 8 pH. Outside of this range, it should be calibrated over a narrow range that brackets the typical process pH. Antimony electrodes should not be used in acid copper solutions nor in oxidizing or reducing solutions such as chromates, chlorine, hypochlorites, or sulfides. Antimony should also not be used in food and beverage applications.

### Platinum and Gold Electrodes

Platinum or gold ORP electrodes are also available. The platinum electrode is the default choice for most ORP applications. The gold electrode is available as an alternate choice, and is primarily used in cyanide reduction systems.

## FIELD INTERCHANGEABLE ELECTRODES

Interchangeable plug-in sensing electrodes are available to satisfy most applications. There is a measuring electrode replacement kit, available by part number, to service each of the electrode choices in the Model Code. All electrodes are compatible with the same basic sensor body. If the measurement conditions or application needs change, it is simple to change from one measurement electrode to another in the field.

## FIELD REPLACEABLE REFERENCE JUNCTION

The reference electrode is a nonflowing type. A silver/silver chloride half cell immersed in saturated potassium chloride is used because of its highly stable output voltage. The filling solution and the ceramic junction may be readily replaced in the field. There is a reference junction replacement kit, available by part number, to service each of the reference junction choices in the Model Code.

For standard process applications, a reference electrode with a single reference junction is recommended. This single junction is available with either a Ryton or ptfе body. As stated previously, the Ryton reference body is to be used with a Ryton sensor, while the ptfе reference body is to be used with a CPVC sensor body.

The patented double junction with ion barrier (Model Code selection D) is recommended for harsh applications containing strong chemical concentrations which tend to poison the reference electrolyte. This junction includes a Nafion ion barrier, in addition to the external ceramic junction. This construction allows charge transfer while minimizing poisoning of the electrode, and preventing silver ion from migrating to the external junction and causing clogging. This junction is made with a PVDF (Kynar) body and is used with either the Ryton or CPVC sensor body.

### SENSOR DIAGNOSTICS

When used with the Foxboro 870ITPH Intelligent Transmitter or 875PH Intelligent Analyzer, the intelligent configurations of the sensor (Sensor Model Code Selections -3, -4, -5, and -6) provide diagnostic information. Sensor health checks will reveal the following faults:

- ▶ Broken glass electrode
- ▶ Aging glass electrode
- ▶ Liquid leakage into sensor body
- ▶ Failure of high impedance amplifier in sensor (Sensor Selection Codes -3 and -4 only)
- ▶ Failure of temperature compensation element
- ▶ Excessive coating of the reference electrode, or sensor not in contact with process water.

### INTEGRAL PREAMPLIFIER

An integral preamplifier (Sensor Model Code Selections -1 through -4) converts the high impedance pH signal to a low impedance signal, which is less prone to interference.

### INTEGRAL AUTOMATIC TEMPERATURE COMPENSATION

Automatic temperature compensation (ATC), utilizing a platinum resistance temperature detector (RTD), is a built-in feature in the 871PH Sensor.

### MOUNTING VERSATILITY

The basic sensor assembly may be mounted:

- ▶ In-line via Ball Valve Assembly
- ▶ In a sample line via Twist-Lock Flow Chambers
- ▶ In-line via Twist-Lock Bushings or Tees
- ▶ In-situ via Electrode Protection Sleeve

See Physical Specifications section for additional information.

### VARIETY OF ACCESSORIES

A variety of process mounting accessories offers a versatile selection to meet virtually all process requirements (see Accessories section).

### INTRINSICALLY SAFE AND NONINCENDIVE DESIGN

The 871PH Sensors have been designed for use in intrinsically safe and hazardous area locations when used with the Foxboro transmitters and analyzers listed in Table 1 or other certified equipment. Refer to MI 611-206 or 611-208 or the certificates for entity parameters.

**Table 1. Transmitters and Analyzers used with 871PH Sensors**

PSS Number	Transmitter and Analyzer Model and Description
PSS 6-1A1 E	Model 875PH Intelligent Electrochemical Analyzer
PSS 6-1B1 B	Model 870ITPH Intelligent Electrochemical Transmitter
PSS 6-1C1 A	Model 870PH Analog Output Transmitter
PSS 6-1C1 E	Model 873PH Electrochemical Analyzer, pH and ORP Model 873DPX Electrochemical Analyzer, pH, ORP, and ISE (uses Dual Sensor Inputs)

**ptfe COLLAR OPTION (SEE FIGURE 1)**

The ptfe collar Option Selection -T is added to the sensing tip of the sensor, and replaces the long keeper screw with a flat head screw.

It is compatible with all of the electrode and junction choices, and protects the electrode sides and junction from abrasion and coating. When used with the flat glass electrode, the collar creates a flat, smooth sensing surface, which is desirable in processes having high coating potential.

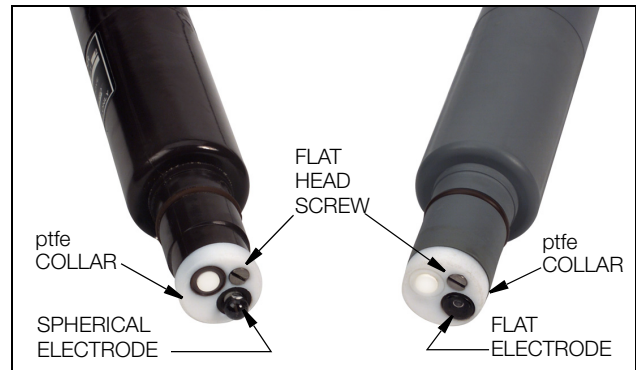

*Figure 1. ptfe Collar (Option -T)  
Shown with Spherical Electrode (left)  
and Flat Glass Electrode (right)*

**PERFORMANCE SPECIFICATION**

**Reproducibility**

Typically ±2 mV dc (0.03 pH unit) at reference conditions. Reproducibility at operating conditions depends on calibration standard used, cleanliness of electrode, and other process-related conditions.

Optional Foxboro electrode cleaners aid in maintaining a high degree of reproducibility on pH and ORP electrodes in dirty process streams. (See Accessories section and PSS 6-1A2 C on Model ECS Electrode Cleaning Systems.)

**PRESSURE AND TEMPERATURE SPECIFICATIONS**

**NOTE**

Maximum allowable temperature and pressure may be limited by installation hardware utilized. Refer also to the temperature and pressure specifications on all appropriate bushings, tees, flow chambers, and ball valve assemblies.

**Ryton Body**

Measuring Electrode Type	Ball Valve or Submersible Installation		In-Line Installation	
	Maximum Pressure	Temperature Range	Maximum Pressure	Temperature Range
Spherical Glass pH	0.7 MPa (100 psi)	-5 to + 80°C (20 to 175°F)	0.7 MPa (100 psi)	-5 to +100°C (20 to 212°F)
Flat Glass pH	1 MPa (150 psi)	-5 to + 80°C (20 to 175°F)	1 MPa (150 psi)	-5 to +85°C (20 to 185°F)
Domed Glass pH	0.7 MPa (100 psi)	0 to 80°C (32 to 175°F)	0.7 MPa (100 psi)	0 to 121°C (32 to 250°F)
Antimony pH	1 MPa (150 psi)	-5 to + 80°C (20 to 175°F)	1 MPa (150 psi)	-5 to +125°C (20 to 255°F)
ORP	1 MPa (150 psi)	-5 to + 80°C (20 to 175°F)	1 MPa (150 psi)	-5 to +125°C (20 to 255°F)

**CPVC Body**

Measuring Electrode Type	Ball Valve or Submersible Installation			In-Line Installation		
	Maximum Pressure at Operating Temperature			Maximum Pressure at Operating Temperature		
Spherical Glass pH	0.7 MPa (100 psi) at -5°C (20°F)	0.6 MPa (90 psi) at 50°C (120°F)	0.3 MPa (50 psi) at 80°C (175°F)	0.7 MPa (100 psi) at -5°C (20°F)	0.3 MPa (50 psi) at 80°C (175°F)	0.1 MPa (15 psi) at 100°C (212°F)
Flat Glass pH	0.9 MPa (125 psi) at -5°C (20°F)			0.9 MPa (125 psi) at -5°C (20°F)		
Domed Glass pH	0.7 MPa (100 psi) at -5°C (20°F)			0.7 MPa (100 psi) at -5°C (20°F)		
Antimony pH	0.9 MPa (125 psi) at -5°C (20°F)			0.9 MPa (125 psi) at -5°C (20°F)		
ORP	0.9 MPa (125 psi) at -5°C (20°F)			0.9 MPa (125 psi) at -5°C (20°F)		

## ELECTRICAL SAFETY SPECIFICATIONS

### 871PH Sensor Electrical Safety Specifications

Testing Laboratory, Type of Protection, and Area Classification	Application Conditions	Electrical Safety Design Code
<b>ATEX</b> Type n energy limited for II 3 GD, EEx nL IIC, Zone 2.	Connect to instrument per MI 611-208. Temperature Class T4 - T6. T110°C - T235°C.	CS-E/ANN
<b>ATEX</b> intrinsically safe for II 1 GD, EEx ia IIC, Zone 0.	Connect to instrument per MI 611-208. Temperature Class T4 - T6. T110°C - T235°C.	CS-E/AAA
<b>FM</b> intrinsically safe for Class I; Division 1, Groups A, B, C, and D; Class II, Division 1, Groups E, F, and G; Class III, Division 1.	Connect to associated apparatus with compatible entity parameters per MI 611-206. Temperature Cl. T4 at 85°C (185°F) maximum ambient.	CS-E/FAA
<b>FM</b> nonincendive for Class I; Division 2, Groups A, B, C, and D; Suitable for Class II, Division 2, Groups F and G; Class III, Division 2.	Connect to associated apparatus with compatible entity parameters per MI 611-206. Temperature Cl. T4 at 85°C (185°F) maximum ambient.	CS-E/FNN

### 871PH Sensor and Transmitter/Analyzer Loop Certifications

Testing Laboratory, Type of Protection, and Area Classification	Application Conditions	Electrical Safety Design Code
<b>CSA</b> Class I, Division 2, Groups A, B, C, and D hazardous locations.	Connect to 873PH/ 873APH. For use with enclosure W, X, Y and Z.	CS-E/CNZ
<b>CSA</b> ; ia.	Connect to 870PH Transmitter. For use with 871PH Style A all configurations.	CS-E/CAA
<b>CSA</b> intrinsically safe for Class I; Division 1, Groups A, B, C, and D; Class II, Division 1, Groups E, F, and G; Class III, Division 1.	Connect to 870ITPH Transmitter per MI 611-206. Temperature Class T3C at 85°C (185°F) maximum ambient.	870ITPH-..CAA
<b>CSA</b> Class I; Division 2, Groups A, B, C, and D; hazardous locations.	Connect to 870PH Transmitter. For use with 871PH Style A all configurations.	CS-A/CN-A
<b>CSA</b> Class I, Division 2, Groups A, B, C, and D.	Connect to certified 873PH Transmitter per MI 611-206. Temperature Class T6.	CS-E/CN-A
<b>CSA</b> suitable for Class I, Division 2, Groups A, B, C, and D; Class II, Division 2, Groups E, F, and G; Class III, Division 2.	Connect to 875PH Transmitter. Supply Voltage -A, -B, -C, -E, and -J. Temperature Class T4 at 85°C (185°F) maximum ambient.	875PH-..C
<b>CSA</b> suitable for Class I, Division 2, Groups A, B, C, and D; Class II, Division 2, Groups F and G; Class III, Division 2.	Connect to 870ITPH Transmitter per MI 611-206. Temperature Class T4.	870ITPH-..CNZ
<b>CSA</b> ordinary locations.	Connect to 870PH Transmitter. For use with 871PH Style A all configurations.	CS-E/CG-A
<b>CSA</b> ordinary locations.	Connect to 873PH/873APH Transmitters. For use with enclosure P, W, X, Y, and Z. Supply Voltage -A, -J, and -E	CS-E/CGZ
<b>CSA</b> ordinary locations.	Connect to 875PH Transmitter. Supply Voltage -A, -B, -C, -E, and -J. Temperature Class T4A at 85°C (185°F) maximum ambient	875PH-..C
<b>CSA</b> ordinary locations.	Connect to 870ITPH Transmitter.	870ITPH-..CAA 870ITPH-..CNZ

Continued on next page

**ELECTRICAL SAFETY SPECIFICATIONS (CONT.)**

**871PH Sensor and Transmitter/Analyzer Loop Certifications (Cont.)**

Testing Laboratory, Type of Protection, and Area Classification	Application Conditions	Electrical Safety Design Code
<b>FM</b> intrinsically safe Class I; Division 1, Groups A, B, C, and D; Class II, Division 1, Groups E, F, and G; Class III, Division 1.	Connect to approved 870PH Transmitter per MI 611-206. Temperature Class T6.	CS-E/FB-A
<b>FM</b> intrinsically safe Class I, II, and III, Division 1, Groups A, B, C, D, E, F, and G.	Connect to 870ITPH Transmitter per MI 611-206. Temperature Class T4.	870ITPH-..FAA
<b>FM</b> ; n.	Connect to 873PH / 873APH Transmitters. For use with enclosure W, X, Y and Z. Supply voltage -A, -J, and -E.	CS-E/FNZ
<b>FM</b> nonincendive Zone 2; Division 2.	Connect to 870PH Transmitter. For use with 871PH Style A all configurations.	CS-A/FN-A
<b>FM</b> nonincendive Class I, Division 2, Groups A, B, C, and D; Class II, Division 2, Groups F and G; Class III, Division 2.	Connect to 875PH Transmitter. Supply Voltage -A, -B, -C, and -J. Temperature Class T4A at 75°C (167°F) maximum ambient.	875PH-..F
<b>FM</b> nonincendive Class I, Division 2, Groups A, B, C, and D; Class II, Division 2, Groups F and G; Class III, Division 2.	Connect to 870ITPH Transmitter per MI 611-206. Temperature Class T4.	870ITPH-..FNZ
<b>FM</b> ordinary locations.	Connect to 873PH / 873APH. For use with enclosure P, W, X, Y and Z.	CS-E/FGZ
<b>FM</b> ordinary locations.	Connect to 875PH Transmitter. Supply Voltage -A, -B, -C, and -J. Temperature Class T4A at 75°C (167°F) maximum ambient.	875PH-..F
<b>FM</b> ordinary locations.	Connect to 870ITPH Transmitter.	870ITPH-..FAA 870ITPH-..FNZ
<b>KEMA</b> intrinsically safe. <b>CENELEC</b> EEx ia, Zone 0.	Connect to 870ITPH-..EAA or equivalent.	CS-E/KA-E

**NOTE**

These sensors have been designed to meet the electrical safety descriptions listed in the table above. For detailed information, or status of testing laboratory approvals, or certifications, contact Foxboro (see back page).



## FUNCTIONAL SPECIFICATIONS

### Reference Electrode

#### NONFLOWING TYPE - SINGLE JUNCTION

871PH-...A (Ceramic; Rytan Body)

871PH-...B (Ceramic; ptfe Body)

#### NONFLOWING TYPE - DOUBLE JUNCTION

871PH-...D (Ceramic; ion Barrier; pvdf)

### Sensor Assembly Immersion/Submersion Depth

50 mm (2 in) minimum; 6 m (20 ft) maximum

### Automatic Temperature Compensation

#### FOR STANDARD CONFIGURATION SENSORS

2-wire platinum RTD, 100  $\Omega$

#### FOR INTELLIGENT CONFIGURATION SENSORS

*871PH-3, -4 Versions*

3-wire platinum RTD, 1000  $\Omega$

*871PH-5, -6 Versions*

2-wire platinum RTD, 1000  $\Omega$

### Minimum Conductivity of Sample

50  $\mu\text{S}/\text{cm}$

### ATC Temperature Limits

-5 and +125°C (20 and 255°F)

### Cable Length

See table below

Cable Selection	Cable Length	
	With Preamp	Without Preamp
Standard	6 m (20 ft)(a)	6 m (20 ft)(a)
Optional	150 m (500 ft)(b) maximum	15 m (50 ft)(c) maximum

(a) Cable is integral with sensor assembly.

(b) Integral cable to 15 m (50 ft). For cable lengths beyond 15 m (50 ft), an extension cable is required.

(c) Integral or extension cable to a maximum total length of 15 m (50 ft).

## PHYSICAL SPECIFICATIONS

### Measuring Electrodes

Plug-in, interchangeable, measuring electrodes.

#### GLASS PH

[Employing high stability silver, silver chloride (Ag/AgCl) internals] Rytan or ptfe body for spherical glass, domed high temperature glass, and flat ruggedized glass electrodes.

#### ANTIMONY PH

Rytan or ctfe body

#### PLATINUM ORP

Rytan or ctfe body

#### GOLD ORP

Rytan or ctfe body

#### O-RINGS

Viton is standard; EPDM and Chemraz are optional.

### Reference Electrode

Nonflowing, with Ag/AgCl internals and saturated potassium chloride (KCl) electrolyte.

#### REFERENCE JUNCTION

Ceramic

#### BODY MATERIAL

Rytan, ptfe, or pvdf

#### O-RINGS

Viton is standard; EPDM and Chemraz are optional

### Wetted Parts

Rytan or CPVC housing and Viton (EPDM and Chemraz are optional) O-ring. For sensor wetted parts materials, see Model Code section.

## PHYSICAL SPECIFICATIONS

### Sensor Mountings

Type	Description
In-Line via Ball Valve Unit Assembly (Figure 2A)	Permits sensor to be removed from process stream or tank, under rated temperature and pressure, without draining the system or resorting to a bypass arrangement.
Sample Line Twist-Lock Flow Chamber (Figure 2B)	Available for clean sample stream applications. A 316 ss flow chamber is recommended for pure water pH measurement.
In-Line via Twist-Lock Bushing (Figure 2C)	For permanent installation in pipeline or tank.
In-Line via Twist-Lock Tee (Figure 2D)	For permanent installation in pipeline.
In-situ (Figure 2E)	In tank or trough, etc. An electrode protection sleeve is required for this use.

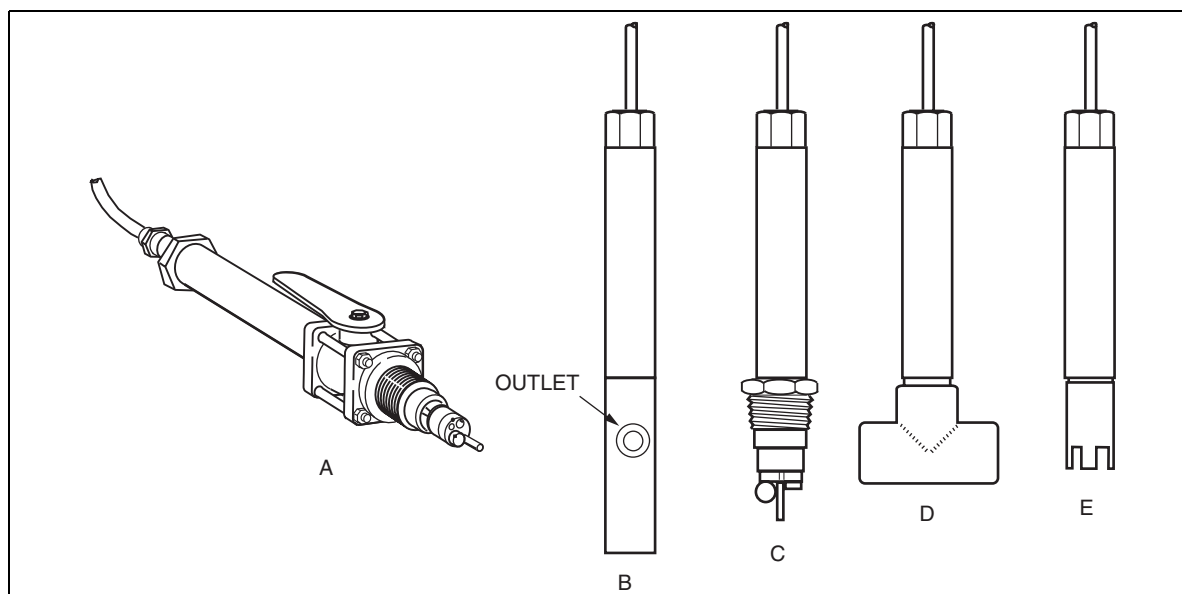

Figure 2. Sensor Mountings

#### Solution Ground (Wetted Material)

Titanium, Carpenter 20 Cb-3, 316L ss, Monel 400, or Tantalum. Solution ground acts as a keeper for securing electrodes in the assembly.

#### Dimensions

Refer to Dimensions - Nominal section.

#### Cable

Integral, 6 m (20 ft), screened PVC-jacketed cable, terminated in numbered straight pin lugs for connection to all Foxboro Transmitters or Analyzers.

#### Shipping Weight

2.3 kg (5 lb)

## ACCESSORIES

### Ball Valve Assemblies

The ball valve assembly (Figure 3) permits a sensor assembly to be inserted and removed from a process stream or tank under rated temperature and pressure without draining the system or resorting to a bypass arrangement. A ball valve assembly consists of the ball valve unit and an insertion shaft assembly; both support a sensor in a stream. A standard flexible conduit (user provided) can be used for cable protection. For additional information, refer to Table 2.

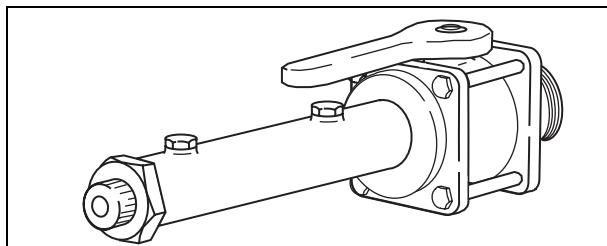

Figure 3. Purgeable Ball Valve Assembly  
(Foxboro Part BS805JP Illustrated)

Table 2. Ball Valve Assembly Specifications

Process Line Connection (in)	Rated Pressure		Max. Temp. at Rated Pressure		Material of Process Wetted Parts (a)				Foxboro Part Number	
	MPa	psi	°C	°F	Process Connection and Housing	Ball Seat	Ball Valve	O-Ring	Purgeable Housing	Non-purgeable Housing
1 1/2 NPT	1.0	145	20	70	316 ss	ptfe	Glass-filled poly-propylene	Viton	BS805JP (b)	BS805JN (c)
	0.4	55	65	150						
	0.07	10	88	190						
1 1/2 NPT	1	145	60	140	Titanium	ptfe	Kynar	Viton	BS805JQ (d)	N/A
	0.6	85	100	212						
	0.4	60	120	250						

(a)Refer to Foxboro for other materials.

(b)Previously specified as Part Number 0051380 plus 0051362 (shaft assembly).

(c)Previously specified as Part Number 0051361 plus 0051362 (shaft assembly).

(d)Previously specified as Part Number 0051360 plus 0051365 (shaft assembly).

ACCESSORIES (CONT.)

**Flow Chambers**

Flow chambers (Figure 4) are a convenient way of mounting sensors in a system where a sample is provided by small diameter sample line. The flow chamber connects to the system via user supplied 1/4 NPT fittings, and provides a chamber for the sample. A flow chamber with sensor in place, will pass up to 125 mL/s (2 gpm) of sample (see Table 3 for specifications).



Figure 4. Flow Chamber  
(Foxboro Part 0051179 Illustrated)

**Plugs**

A plug (Figure 5) replaces a sensor to provide system sealing (if a sensor is removed from the process for maintenance, cleaning, etc.). The plug is compatible with any Foxboro Twist-Lock receptacle (e.g., flow chamber, bushing, tee, etc.) (see Table 4 for specifications).



Figure 5. Plug (Foxboro Part 0051188 Illustrated)

Table 3. Flow Chamber Specifications

Material	Rated Pressure at Rated Temperature				Foxboro Part
	MPa	psi	°C	°F	
PVC	0.4	60	50	120	0051181
	0.2	30	60	140	
316 ss	1.4	200	125	260	0051179

Table 4. Plug Specifications

Material	Rated Pressure at Rated Temperature				Foxboro Part
	MPa	psi	°C	°F	
PVC	0.4	60	50	120	0051187
	0.2	30	60	140	
316 ss	1.4	200	125	260	0051188

ACCESSORIES (CONT.)

**Bushings**

Bushings (Figure 6) may be used to mount sensors in a system using process piping larger than DN 20 or 3/4 in piping. A Twist-Lock connection secures the sensor into the bushing (see Table 5 for specifications).

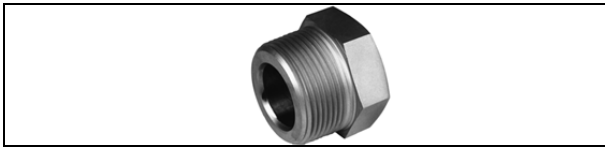

Figure 6. Bushing  
(Foxboro Part 0051185 Illustrated)

Table 5. Bushing Specifications

Mat'l	Thread Size (NPT)	Rated Pressure at Rated Temperature				Foxboro Part
		MPa	psi	°C	°F	
PVC	1 1/4	0.4	60	50	120	0051183
		0.2	30	60	140	
316 ss	1 1/4	1.4	200	125	260	0051185
	1 1/2					0051186

**Tee**

A solvent weld DN 25 or 1 in PVC tee (Figure 7) is available for insertion in a pipeline. Mating to a sensor is achieved via a Twist-Lock connection (see Table 6 for specifications).

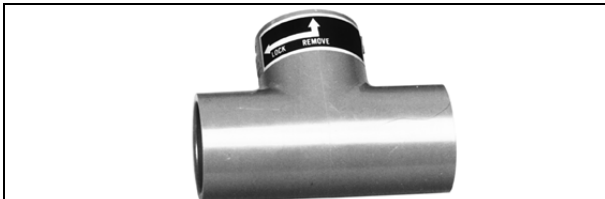

Figure 7. Tee  
(Foxboro Part 0051184 Illustrated)

Table 6. Tee Specifications

Mat'l	Rated Pressure at Rated Temperature				Nominal Length		Foxboro Part
	MPa	psi	°C	°F	mm	in	
PVC	0.4	60	50	120	95	3.8	0051184
	0.2	30	60	140			

**Electrode Protection Sleeve**

The electrode protection sleeve (Foxboro Part 0051189), Figure 8, protects glass electrodes from contacting the bottom or side of a tank. This PVC sleeve (with a maximum temperature rating of 60°C {140°F}) is available for submersible or ball valve assembly applications.



Figure 8. Electrode Protection Sleeve  
(Foxboro Part 0051189)

ACCESSORIES (CONT.)

**Junction Boxes - Surface Mounted**

Three junction boxes are offered that provide the cabling interconnection between the sensor and transmitter or analyzer. They can be used with sensors having or not having an integral preamplifier. (Junction boxes are simply interconnection devices and do not have preamplifiers. Refer to Remote Preamplifier section that follows.) There is a generous amount of space within each junction box to accommodate the terminal blocks, and the sensor and transmitter/analyzer cable assembly terminations. These junction boxes have the dusttight and weatherproof rating of IP65 as defined by IEC 60529, and provide the NEMA ratings listed in Table 7. Refer to Figures 9 and 18.

**Table 7. Junction Box Part Numbers and Application**

Junction Box Part No.	Junction Box used with Sensors Listed Below (a)	Sensor has Integral Preamp.	Junction Box NEMA Rating
BS813XN	871PH-5, -6	NO	4X
0051052	871PH-1, -2 only	YES	4
BS807BZ	871PH-3, -4 only	YES	6

(a) Extension cables or patch cords can be provided. See Figures 17, 16, and 18.

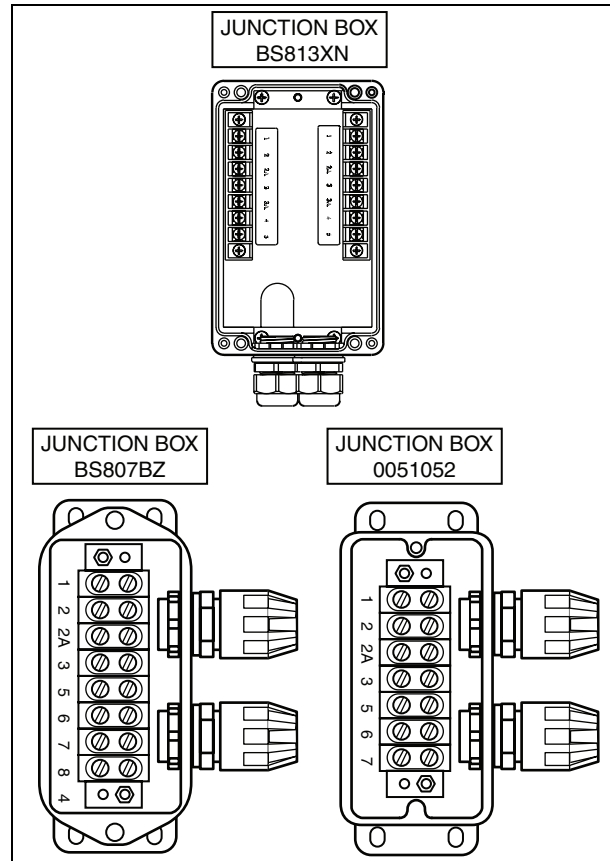

Figure 9. Junction Boxes and Part Numbers Shown with Covers Removed

### ACCESSORIES (CONT.)

#### Remote Preampifier

Certain installations require a sensor without an integral preamplifier, but still must connect to a transmitter or analyzer with a cabling distance more than 15 m (50 ft) away. In this situation, a junction box with a remote preamplifier is provided that interconnects the sensor and transmitter/analyzer with a total cable length up to 150 m (500 ft) maximum. The junction box enclosure has a NEMA 4X rating that provides weatherproof, dustproof, and corrosion resistant protection. See Table 8 and Figures 10 and 18.

**Table 8. Remote Preamplifier Application**

Junction Box with Remote Preamplifier Part No.	Junction Box with Remote Preamplifier used with Sensors Listed Below	Enclosure Rating
BS811MR	871PH-5, -6 (a)	NEMA 4X

(a) Extension cables can be provided. See Table 11.

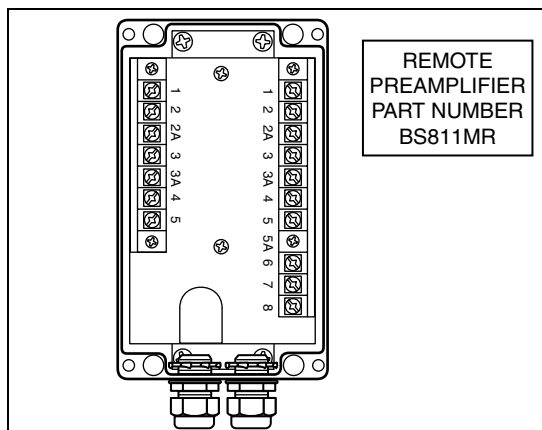

Figure 10. Junction Box with Remote Preamplifier

#### Patch Cord with Generic Connector

These patch cords provide connections between a generic sensor and either a transmitter or analyzer. There is a generic connector socket on one end of the patch cord that mates with a generic connector plug on the 871PH-....-5 or 871PH-....-7 sensor

assembly. The patch cord has leads with straight pin lugs on the other end that connect to the transmitter or analyzer. They are offered in 15 m (50 ft) lengths, or lengths up to 150 m (500 ft). See Figures 11 and 16. Also see Table 11 for part numbers of patch cords with generic connectors.

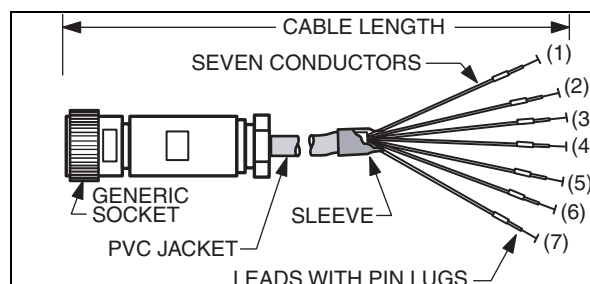

Figure 11. Patch Cord with Generic Connector Socket

#### Patch Cord with Variopin Quick Connector

This patch cord has a Variopin quick connector on one end and straight pin lugs on the other end. This patch cord is also used with 871PH-1 or 871PH-2 sensors, and is the mating cable between the sensor assembly and transmitter or analyzer. The connector is rated IP 67, with nickel plating and Viton O-rings. This patch cord is used with sensor assemblies 871PH-....-B or 871PH-....-Q. See Figures 12 and 17. Also see Table 11 for part numbers of patch cords with Variopin connectors.

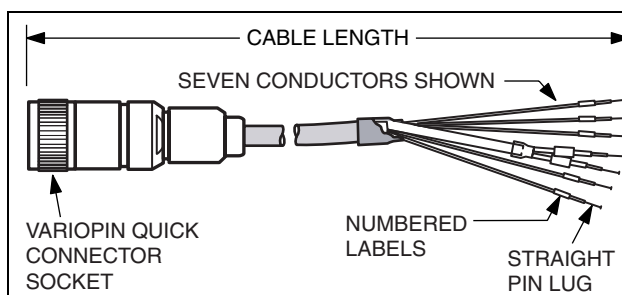

Figure 12. Patch Cord with Variopin Quick Connector Socket

**ACCESSORIES (CONT.)**

**Extension Cables**

These multi-conductor PVC-jacketed extension cables provide intrasystem connections.

For sensors without an integral preamplifier, or for systems without a remote preamplifier, these extension cables are offered with straight pin lugs on both ends with cable lengths of 3, 6, 9, 12, or 15 m (10, 20, 30, 40, or 50 ft). Refer to Figures 13 and 18.

For sensors with an integral preamplifier, or for systems with a remote preamplifier, these extension cables are offered with straight pin lugs on both ends with a cable length specified by the user, but not exceeding 150 m (500 ft). Refer to Table 11, and Figures 14 and 18.

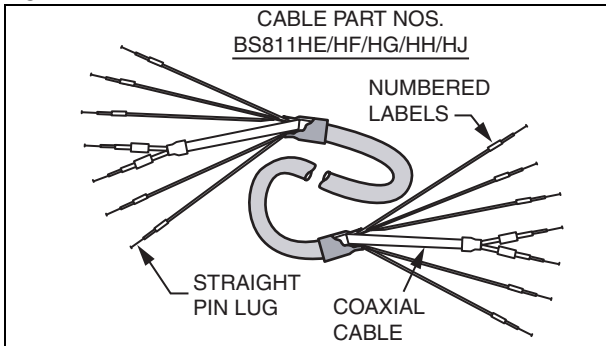

*Figure 13. Extension Cable Assemblies when No Preamplifier is used*

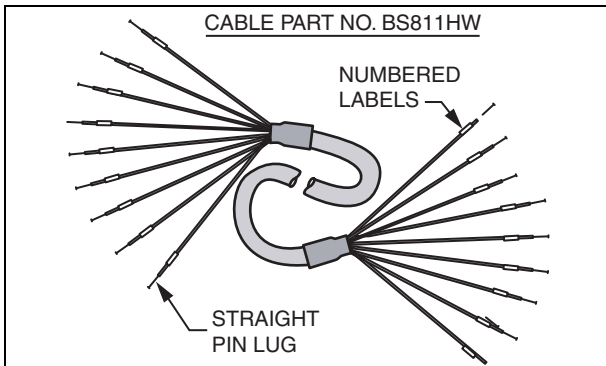

*Figure 14. Extension Cable Assembly when a Preamplifier is used*

**Raw Underterminated Cable**

Multi-conductor, PVC-jacketed, raw, unterminated cable is also offered for intrasystem connections for use with sensors with or without an integral preamplifier, or with or without a remote preamplifier. Raw Cable Part Number P0170UU is used when there is no preamplifier in the system, while Part Number P0170UV is used when there is a preamplifier in the system. These unterminated cables are offered in continuous lengths up to 300 m (1000 ft), on a per meter or per foot basis. Refer to Figure 15 and Table 11.

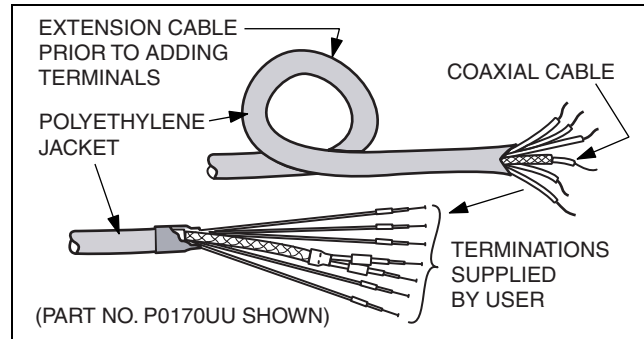

*Figure 15. Raw, Unterminated Cable*

**High Temperature Cable Integral to Sensor Assembly**

High temperature cable integral to the sensor assembly is offered for use with 871PH-5 or 871PH-6 sensors that do not have an integral preamplifier. This high temperature integral cable has an irradiated, cross-linked polyethylene jacket rated to 125°C (255°F). The cable integral to the sensor is available in lengths up to 15 m (50 ft). The optional high temperature integral cable is Optional Selection -H. See Table 11 for part number.



ACCESSORIES (CONT.)

Accessories used for Intra System Cabling

Figures 17, 16, and 18 depict the typical interconnections between a sensor and a transmitter or analyzer. Note that the interconnection topography varies depending on the sensor, junction box, remote amplifier, extension cable, or patch cord used. Also note that when the sensor has an integral preamplifier, or when a remote preamplifier is used, the cabling length can be up to, but not more than, 150 m (500 ft). When there is no preamplifier, the maximum cabling length allowed between sensor and transmitter or analyzer is 15 m (50 ft). Patch cords, extension cables, junction boxes, or a remote amplifier can be provided for the installation required. Refer to Table 11 for patch cord and extension cable descriptions and part numbers.

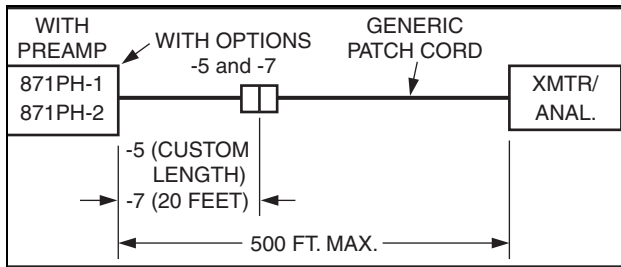

Figure 16. System Installation Topologies using Patch Cords with Generic Connector

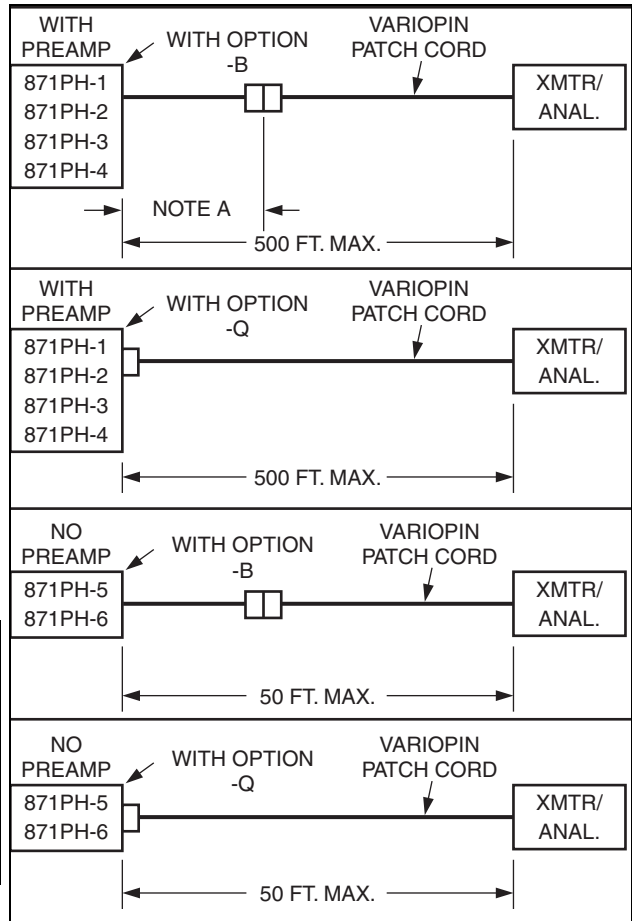

Figure 17. System Installation Topologies using Patch Cord with Variopin Quick Connector

ACCESSORIES (CONT.)

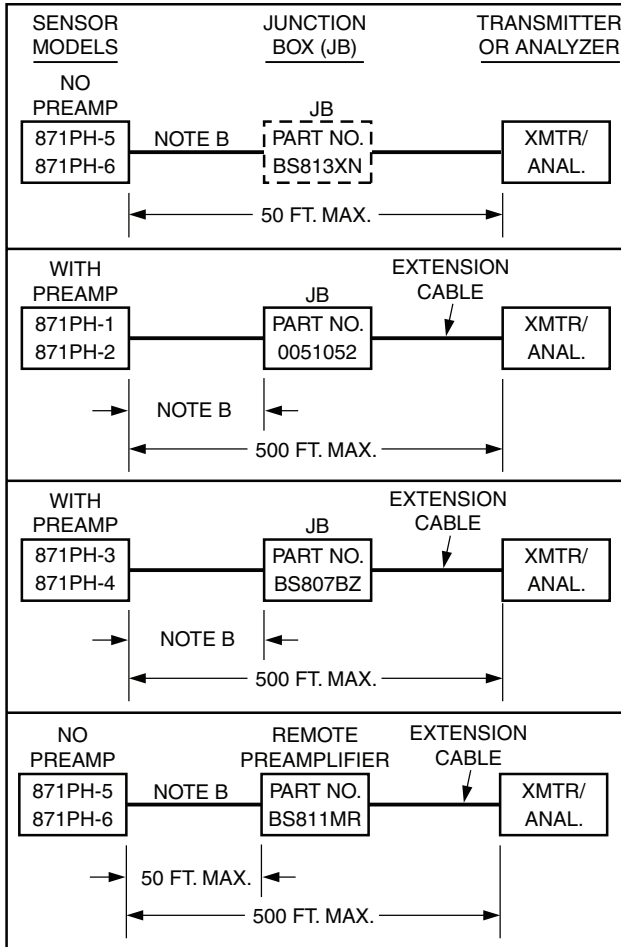

Figure 18. System Installation Topologies using Extension Cables

NOTE

- A. 6 m (20 ft) standard; add Options -3B for length per Sales Order for a total combined length of 150 m (500 ft).
- B. 6 m (20 ft) standard; use Option -3 for length per Sales Order up to the maximum allowed. Maximum is 15 m (50 ft) for sensors without a preamplifier (Codes -5 and -6), and maximum is 150 m (500 ft) for sensors with a preamplifier (Codes -1 to -4).

Buffers for use with 871PH Sensors

Buffers are available as a solution, or in a salt packet. When provided in a salt packet, the buffer is mixed with 0.47 liters (16 fluid ounces) of distilled water to convert to a buffer solution. See Table 9 for Buffer Solution and Salt Packet part numbers.

Table 9. Table of Buffer Solutions and Salt Packets

Type	Buffer Description	Part No.
Solution	4.00 pH, 0.47 L (16 fl oz)	Q0104KC
	7.00 pH, 0.47 L (16 fl oz)	Q0104KB
	10.00 pH, 0.47 L (16 fl oz)	Q0104KA
Salt Packet	4.00 pH (Note a)	1600100
	7.00 pH (Note a)	1600101
	10.00 pH (Note a)	1600102

(a) Mix buffer packet with 0.47 L (16 fl. oz.) of distilled water to convert to solution form.

Electrode Cleaning System

The Model ECS Electrode Cleaning system comprises a family of automatic in-line electrode cleaners used exclusively with many Foxboro pH and ORP sensors, including the 871A sensor. The continuous rotation of the cleaning element across the measuring element(s) minimizes or totally eliminates physical coatings that interfere with obtaining accurate measurements. The Model ECS is offered in various flow-through and submersible assembly configurations. Refer to PSS 6-1A2 C for configurations available, specifications, and ordering instructions.

Electrode Kits, Multi-Electrode Kits, Reference Cavity Refill Kits, Multireference Cavity Refill Kits, and Reference Cavity Filling Solution

Refer to Table 10. It is recommended that an additional Electrode Kit and a Reference Cavity Refill Kit be ordered with a basic system.

Table 10. Kits

Kit Description	Kit Part No.
<p><b>Electrode Kit:</b> To allow for immediate replacement of critical measuring electrode and components. Contains electrode replacement, locking keeper and stud, and electrode removal tool. Titanium wetted parts and Viton O-rings are standard, unless otherwise noted. Other O-rings and metals are available. Contact Foxboro.</p> <ul style="list-style-type: none"> <li>Spherical Glass pH, Ryton body</li> <li>Spherical Glass pH, ptfe body</li> <li>High Temperature, domed, DolpHin Glass pH, Ryton Body</li> <li>High Temperature, domed, DolpHin Glass pH, ptfe Body</li> <li>Flat Ruggedized Glass pH, Ryton Body</li> <li>Flat Ruggedized Glass pH, ptfe Body</li> <li>Glass pH, for use with Electrode Cleaning Systems. Similar to above except with short titanium screw in place of keeper stud.</li> <li>Antimony pH, Ryton Body</li> <li>Antimony pH, ctfe Body, Monel metal</li> <li>Antimony pH, ctfe Body, C-20 metal</li> <li>Platinum ORP, Ryton Body</li> <li>Platinum ORP, ctfe Body</li> <li>Gold ORP, Ryton Body</li> </ul>	<ul style="list-style-type: none"> <li>0022505</li> <li>0022510</li> <li>BS812CY</li> <li>BS812DQ</li> <li>BS805MD</li> <li>BS812BZ</li> <li>0022504</li> <li>0022506</li> <li>BS812FA</li> <li>BS812EY</li> <li>0022507</li> <li>0022532</li> <li>0022508</li> </ul>
<p><b>Multi-Electrode Kit:</b> Contains 10 measuring electrodes, 1 locking keeper and stud, and 1 electrode removal tool. Titanium wetted parts and Viton O-rings are standard.</p> <ul style="list-style-type: none"> <li>Spherical Glass pH, Ryton body</li> <li>Spherical Glass pH, ptfe body</li> <li>High Temperature, domed, DolpHin Glass pH, Ryton Body</li> <li>High Temperature, domed, DolpHin Glass pH, ptfe Body</li> <li>Flat Ruggedized Glass pH, Ryton Body</li> <li>Antimony pH, Ryton Body</li> </ul>	<ul style="list-style-type: none"> <li>BS805WC</li> <li>BS805YN</li> <li>BS812KZ</li> <li>BS812KY</li> <li>BS805WD</li> <li>BS805WM</li> </ul>
<p><b>Reference Cavity Refill Kit:</b> To allow for immediate replacement of critical reference junction and components. Contains ceramic reference junction, replacement locking keeper and stud, removal tool, and electrolyte solution. Titanium wetted parts and Viton O-rings are standard.</p> <ul style="list-style-type: none"> <li>Standard Junction with Ryton Body</li> <li>Standard Junction with ptfe Body</li> <li>Double Junction with ion barrier, PVDF Body</li> </ul>	<ul style="list-style-type: none"> <li>0022703</li> <li>0022705</li> <li>BS812KG</li> </ul>
<p><b>Multireference Cavity Refill Kit:</b> Contains 10 ceramic reference junctions, 1 locking keeper and stud, 1 electrode removal tool, and 500 mL of electrolyte solution. Titanium wetted parts and Viton O-rings are standard.</p> <ul style="list-style-type: none"> <li>Standard Junction with Ryton Body</li> <li>Standard Junction with ptfe Body</li> <li>Double Junction with ion barrier, PVDF Body</li> </ul>	<ul style="list-style-type: none"> <li>BS805YP</li> <li>BS805YQ</li> <li>BS812KX</li> </ul>
<p><b>Reference Cavity Filling Solution:</b> Concentrated KCl, 500 mL</p>	<ul style="list-style-type: none"> <li>BS805YR</li> </ul>

**NOTE**

The kits listed in Table 10 are the most widely used kits with the 871PH Sensor Assembly. For a complete listing of available kits, refer to Parts List PL 611-014.

Table 11. Patch Cord, Extension Cable, and Raw Cable Part Numbers

<b>Patch Cords with a Generic Connector Socket Used with Sensors with Standard Configuration and an Integral Pre-amplifier</b>					
Part Number	Temperature Limit	Sensor Model	Cable Option Code	Terminations	Nominal Cable Length (a)
BS806NP	Std. Temp. 85°C (185°F)	871PH-1, -2	-7	Generic Connector Socket on one end; and straight pin lugs on other end	3 m (10 ft) (a)
BS806NQ			-5		to 150 m (to 500 ft) (b)
<p>(a) Standard cable length for all transmitters/analyzers; tolerance is +0.3, -0 m (+1, -0 ft).</p> <p>(b) Nonstandard cable length per Sales Order; tolerance is +5%, -0% of length specified; 150 m (500 ft) maximum except for 870PH Transmitter, which is 33 m (100 ft) maximum.</p>					
<b>Patch Cords with Variopin Quick Connect Socket Used with Sensors without an Integral Pre-amplifier</b>					
Part Number	Temperature Limit	Sensor Model	Cable Option Code	Terminations	Length
BS811GU	Std. Temp. 85°C (185°F)	871PH-5, -6	-B and -Q	Variopin Quick Connect Socket on one end; and straight pin lugs on other end	3 m (10 ft)
BS811GV					6 m (20 ft)
BS811GW					9 m (30 ft)
BS811GX					12 m (40 ft)
BS811GY					15 m (50 ft)
BS810QA	High Temp. 125°C (255°F)	871PH-5, -6	-B and -Q	Variopin Quick Connect Socket on one end; and straight pin lugs on other end	3 m (10 ft)
BS810QB					6 m (20 ft)
BS810QC					9 m (30 ft)
BS810QD					12 m (40 ft)
BS810QE					15 m (50 ft)
NOTE: Cable tolerance is +0.3, -0 m (+1, -0 ft).					
<b>Patch Cords with Variopin Quick Connect Socket Used with Sensors with an Integral Pre-amplifier</b>					
Part Number	Temperature Limit	Sensor Model	Cable Option Code	Terminations	Length
BS811JB	Std. Temp. 85°C (185°F)	871PH-1, -2, -3, and -4	-B and -Q	Variopin Quick Connect Socket on one end; and straight pin lugs on other end	to 150 m (to 500 ft) (a)
(a) Nonstandard cable length per Sales Order; tolerance is +5%, -0% of length specified; 150 m (500 ft) maximum except for 870PH Transmitter, which is 33 m (100 ft) maximum.					

Table 11 continued on next page.

Table 11. Patch Cord, Extension Cable, and Raw Cable Part Numbers (Cont.)

<b>Extension Cable used with Sensor without an Integral Preampfier, and without a Remote Preampfier</b>				
<b>Part Number</b>	<b>Temperature Limit</b>	<b>Sensor Model</b>	<b>Terminations</b>	<b>Length</b>
BS811HE	Std. Temp. 85°C (185°F)	871PH-5, -6	Straight Pin Lugs on Both Ends	3 m (10 ft)
BS811HF		871PH-5, -6		6 m (20 ft)
BS811HG		871PH-5, -6		9 m (30 ft)
BS811HH		871PH-5, -6		12 m (40 ft)
BS811HJ		871PH-5, -6		15 m (50 ft)
<b>Extension Cable used with Sensor having an Integral Preampfier, or a System with a Remote Preampfier (a)</b>				
<b>Part Number</b>	<b>Temperature Limit</b>	<b>Sensor Model</b>	<b>Terminations</b>	<b>Length</b>
BS811HW	Std. Temp. 85°C (185°F)	871PH-1, -2, -3, and -4 Note (b)	Straight Pin Lugs on Both Ends	to 150 m (to 500 ft) (c)
<p>(a) Remote preampfier part number is BS811MR.</p> <p>(b) Not for use with Sensor Model Options -5, -7, -H, -B, or -Q. These sensors require patch cords.</p> <p>(c) Specify extension cable length up to a maximum of 150 m (500 ft).</p>				
<b>Raw Cable, Unterminated, for Users who wish to make their own Extension Cable</b>				
<b>Part Number</b>	<b>Temperature Limit</b>	<b>Sensor Model</b>	<b>Terminations</b>	<b>Length</b>
P0170UU (a)	Std. Temp. 85°C (185°F)	871PH-5, -6	This raw, unterminated cable is ordered in lengths to 300 m (1000 ft), on a per meter or per foot basis.	up to 300m (up to 1000 ft)
P0170UV (b)		871PH-1, -2, -3, and -4		
<p>(a) Five conductor cable (1 coaxial plus 4 primary) with PVC jacketed shield. For use when there is no preampfier in the system.</p> <p>(b) Eight conductor cable with an overall shield and drain wire, all PVC jacketed. For use with Remote Preampfier Part Number BS811MR, or with a sensor having an integral preampfier.</p>				

**MODEL CODE**

<u>Description</u>	<u>Model</u>
Rebuildable Style pH/ORP Sensor	871PH
<b><u>Sensor Body Material and Diagnostic Configuration</u></b>	
<b><u>(See Table 12 on next page for Sensor/Analyzer/Transmitter Compatibility)</u></b>	
Ryton, Standard Configuration, Integral 6 m (20 ft) Cable, Integral Preamplifier (a)	-1
CPVC, Standard Configuration, Integral 6 m (20 ft) Cable, Integral Preamplifier (a)	-2
Ryton, Intelligent Configuration, Integral 6 m (20 ft) Cable, Integral Preamplifier (b)	-3
CPVC, Intelligent Configuration, Integral 6 m (20 ft) Cable, Integral Preamplifier (b)	-4
Ryton, Intelligent Configuration, Integral 6 m (20 ft) Cable, No Preamplifier (b)	-5
CPVC, Intelligent Configuration, Integral 6 m (20 ft) Cable, No Preamplifier (b)	-6
<b><u>Measuring Electrode and Body Material</u></b>	
Spherical Glass, pH, Ryton	A
Antimony, pH, Ryton	B
Platinum, ORP, Ryton	D
Gold, ORP, Ryton	E
Flat Ruggedized Glass, pH, Ryton (c)	F
Domed High Temperature Glass, pH, Ryton	G
Spherical Glass, pH, ptfe	P
Antimony pH, ctfe	Q
Platinum, ORP, ctfe	R
Gold, ORP, ctfe	S
Flat Ruggedized Glass, pH, ptfe (c)	T
Domed High Temperature Glass, pH, ptfe	U
None	X
<b><u>Sensor Wetted Metallic Parts Material</u></b>	
Titanium	1
Carpenter 20 Cb	2
AISI Type 316L Stainless Steel (316L ss)	3
Monel	5
Tantalum	6
<b><u>Reference Junction and Body Material</u></b>	
Ceramic, Ryton	A
Ceramic, ptfe	B
Ceramic, Double Junction, Ion Barrier, pvdf	D
<b><u>Optional Selections</u></b>	
<b><u>Cable: Integral to Sensor: Standard and High Temperature</u></b>	
Nonstandard Integral Cable Length, standard temperature at 85°C (185°F); Not available with Option -Q (d)	-3
Nonstandard Integral Cable Length, terminated in generic connector plug; standard temperature at 85°C (185°F); specify length; Not available with Options -4, -B, -Q, -H) (d)(e)(f)(g)	-5
Standard Integral Cable Length 6 m (20 ft), terminated in generic connector plug; standard temperature at 85°C (185°F); Not available with Options -4, -B, -Q, -H) (e)(f)(g)	-7
Integral High Temperature Cable rated 125°C (255°F) (with Sensor Body -5, -6; Not available with Options -5, -7, -Q)	-H
<b><u>Variopin Quick Connector on Integral Cable or Sensor Body</u></b>	
Integral Cable Terminated w/Variopin Quick Connector (not available with Options -4, -5, -7) (f)(j)	-B
Variopin Quick Connector Integral to Sensor Body (not available with Options -3, -4, -5, -7, -H) (f)(j)	-Q
<b><u>O-Rings</u></b>	
EPDM O-Rings (standard O-rings are Viton)	-E
Chemraz O-Rings (standard O-rings are Viton)	-C

**Model Code continued on next page**

**MODEL CODE (CONTINUED)**

<b>Optional Selections (Con.)</b>	
<b>Miscellaneous Optional Selections</b> No spade lug terminals attached to end of cable (not available with Option -5, -7, -B, -Q) (h) ptfe Collar	-4 -T
Example: 871PH-1F1A-4	

- (a) Does not support the sensor diagnostic features of 870ITPH Transmitter and 875PH Analyzer.
- (b) Compatible with 870ITPH Intelligent Transmitter and 875PH Analyzer only.
- (c) Optimum accuracy is in the range of 2 to 12 pH. It can, however, be used with pH instruments ranged from 0 to 14 pH.
- (d) Standard cable length if not specified = 6 m (20 ft).  
Maximum integral cable length with Transmitters or Analyzers is:  
33 m (100 ft) for 870PH pH/ORP transmitters;  
150 m (500 ft) for 870ITPH Transmitters, and for 873PH, 873APH, and 873DPX, and 875PH Analyzers.
- (e) Requires Patch Cable. See Accessories section.
- (f) Not compatible with ball valve assembly mountings.
- (g) Compatible with 871PH-1 and 871PH-2 only; this option is NOT a Variopin style connector.
- (h) All cables that do not have connectors, have leads terminated with straight pin lugs, and are now compatible with all Foxboro Analyzers and Transmitters. Option -4 is no longer required for compatibility with 873 Series. Option -4 is included for customers who automatically order it.
- (j) When used with 871PH-3, -4, the standard 3-wire 1000 ohm RTD is supplied as a 2-wire, 1000 ohm RTD.

**Table 12. Sensor/Analyzer/Transmitter Compatibility**

Instrument	Sensor Signal Conditioning Code (a)		
	871PH-1, -2 (b)	871PH-3, -4	871PH-5, -6
875PH Intelligent Analyzer (b)	150 m (500 ft) maximum	150 m (500 ft) maximum	15 m (50 ft) maximum
873PH Analyzer	150 m (500 ft) maximum	Not Compatible	Not Compatible
873DPX Analyzer	150 m (500 ft) maximum	Not Compatible	Not Compatible
870ITPH Intelligent Transmitter	150 m (500 ft) maximum	150 m (500 ft) maximum	15 m (50 ft) maximum
870PH Transmitter	30 m (100 ft) maximum	Not Compatible	Not Compatible

- (a) Maximum = Maximum allowable cable length between sensor and analyzer or transmitter.
- (b) 875PH Analyzer and 870ITPH Transmitter when used with 871PH-1 or -2 Sensor are compatible but without the full diagnostic suite.

**DIMENSIONS-NOMINAL**

mm  
in

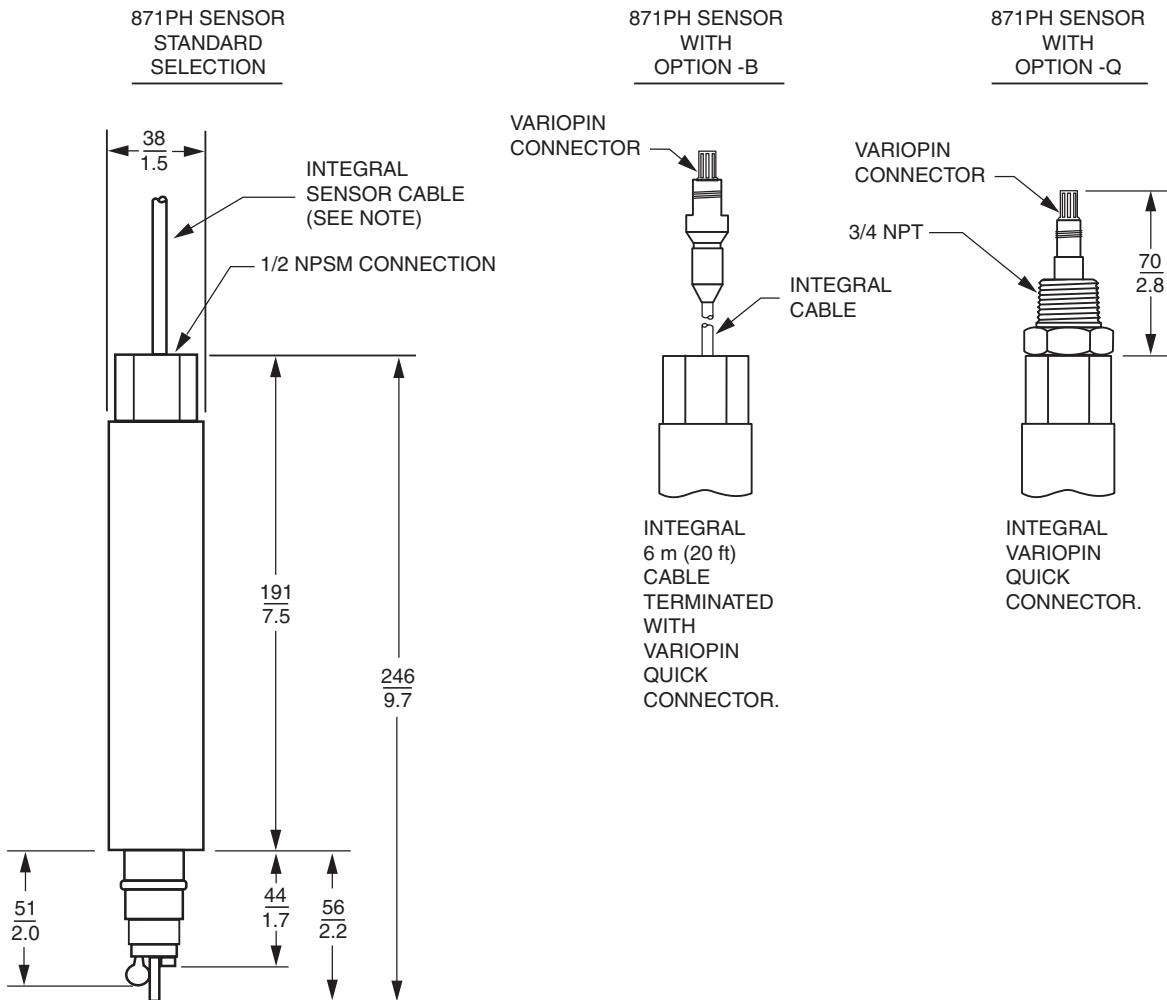

**NOTE:**

THE STANDARD INTEGRAL CABLE LENGTH IS 6 m (20 ft), AND TERMINATED WITH STRAIGHT PIN LUGS. THE INTEGRAL STANDARD CABLE IS RATED AT 85°C (185°F). OPTIONAL INTEGRAL CABLES, AND ALSO HIGH TEMPERATURE CABLE RATED AT 125°C (255°F), ARE AVAILABLE.



DIMENSIONS-NOMINAL (CONT.)

mm  
in

SENSOR ACCESSORIES

BUSHINGS

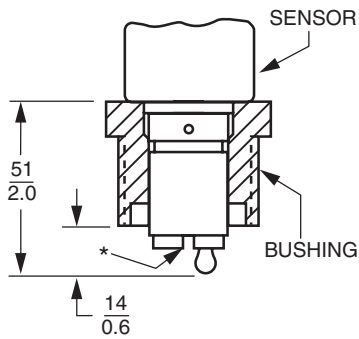

1 1/4 NPT (PVC)  
FOXBORO PART 0051183

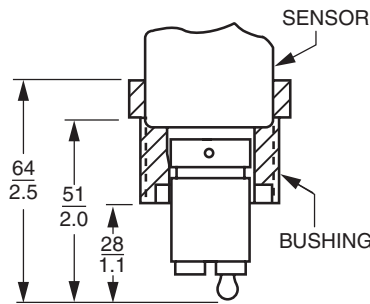

1 1/4 NPT (316 ss)  
FOXBORO PART 0051185

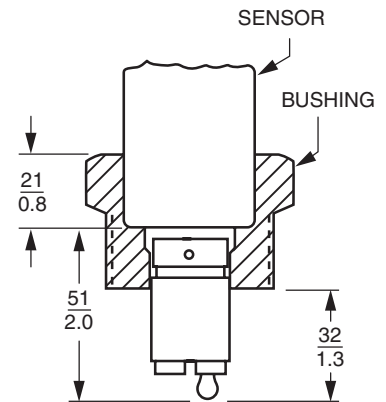

1 1/2 NPT (316 ss)  
FOXBORO PART 0051186

ELECTRODE PROTECTION SLEEVE

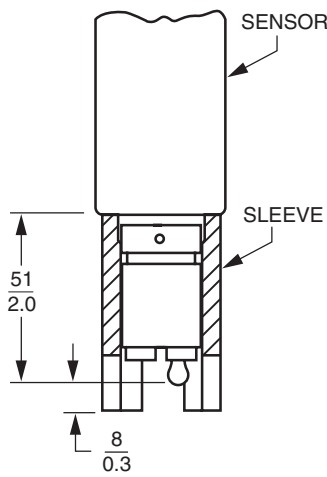

PVC  
FOXBORO PART 0051189

FLOW CHAMBER

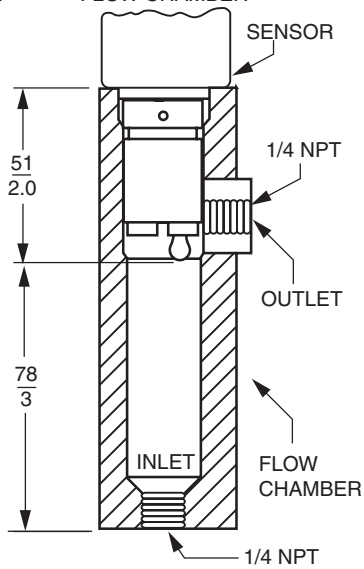

PVC  
FOXBORO PART 0051181  
316 ss  
FOXBORO PART 0051179

TEE

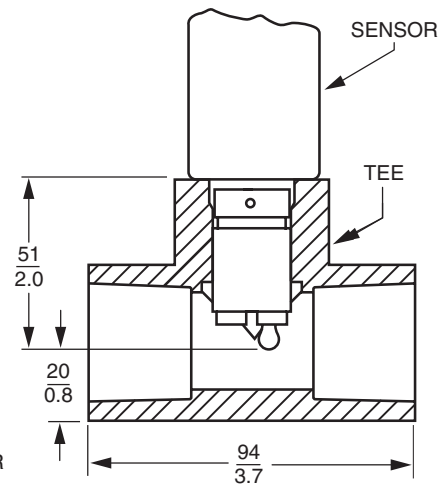

DN 25 OR 1 in (PVC)  
FOXBORO PART 0051184

\* FOR DIMENSIONS WITH KEEPER STUD, REFER TO PREVIOUS PAGE.

**DIMENSIONS-NOMINAL (CONT.)**

$\frac{\text{mm}}{\text{in}}$

**SENSOR ACCESSORIES (Cont.)**

**BALL VALVE ASSEMBLY WITH 316 SS PROCESS CONNECTION AND HOUSING**

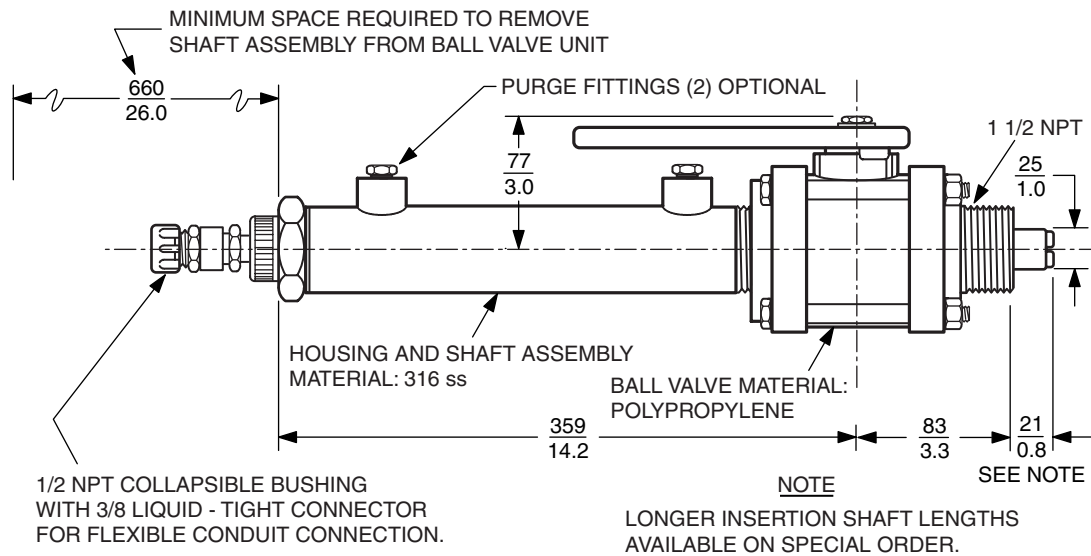

Description	Foxboro Part
With Purgeable Housing	BS805JP (a)
With Nonpurgeable Housing	BS805JN (b)

(a) Previously specified as 0051380 plus 0051362.

DIMENSIONS-NOMINAL (CONT.)

$\frac{\text{mm}}{\text{in}}$

SENSOR ACCESSORIES (Cont.)

BALL VALVE ASSEMBLY WITH TITANIUM PROCESS CONNECTION AND HOUSING

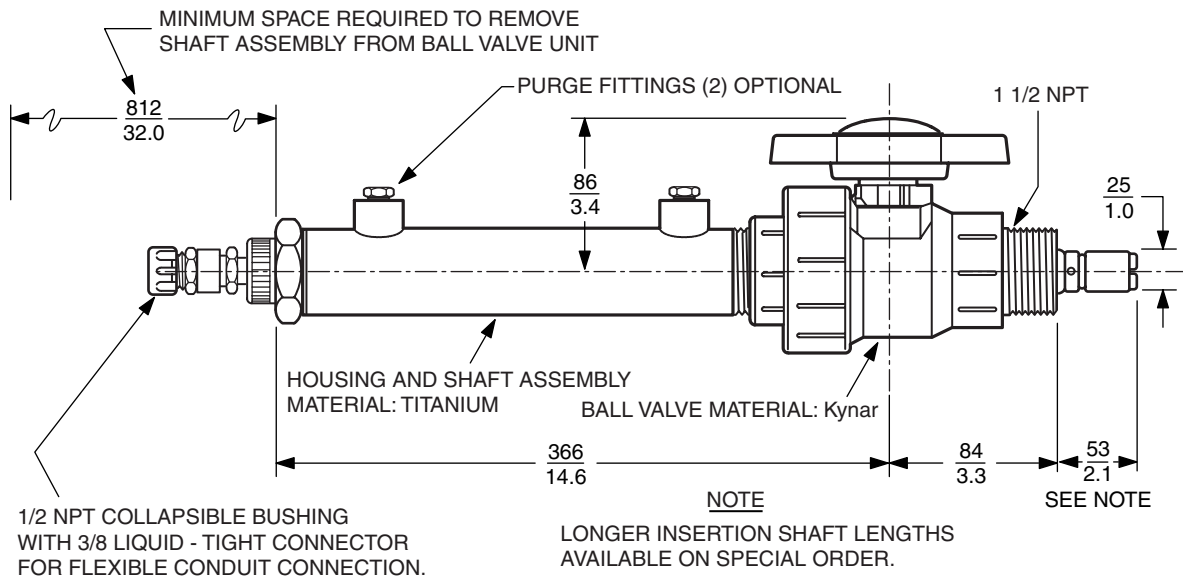

Description	Foxboro Part
With Purgeable Housing	BS805JQ (a)

(a) Previously specified as 0051360 plus 0051365.

## ORDERING INSTRUCTIONS

1. Model Number.
2. Electrical Safety Design Code, if needed (see Electrical Safety Specifications section).
3. Cable length, if nonstandard.
4. Mounting hardware, if required.
5. Cable and junction box, or patch cord, if required.
6. Accessories, if required.
7. Customer Tag Data.

## OTHER M&I PRODUCTS

Foxboro provides a broad range of measurement and instrument products, including solutions for pressure, flow, analytical, positioners, temperature, controlling and recording. For a listing of these offerings, visit the Invensys Operations Management web site at:

[www.iom.invensys.com](http://www.iom.invensys.com)

Invensys Operations Management  
5601 Granite Parkway Suite 1000  
Plano, TX 75024  
United States of America  
<http://www.iom.invensys.com>

Global Client Support  
Inside U.S.: 1-866-746-6477  
Outside U.S.: 1-508-549-2424 or contact  
your local Invensys representative.  
Email: [support@invensys.com](mailto:support@invensys.com)  
Website: <http://support.ips.invensys.com>

Invensys, Foxboro, and DolpHin are trademarks of Invensys plc, its subsidiaries, and affiliates. All other brand names may be trademarks of their respective owners.

Copyright 1990-2010 Invensys Systems, Inc.  
All rights reserved

MB 010, 012

0410