

Type 37 Diaphragm Measuring Element

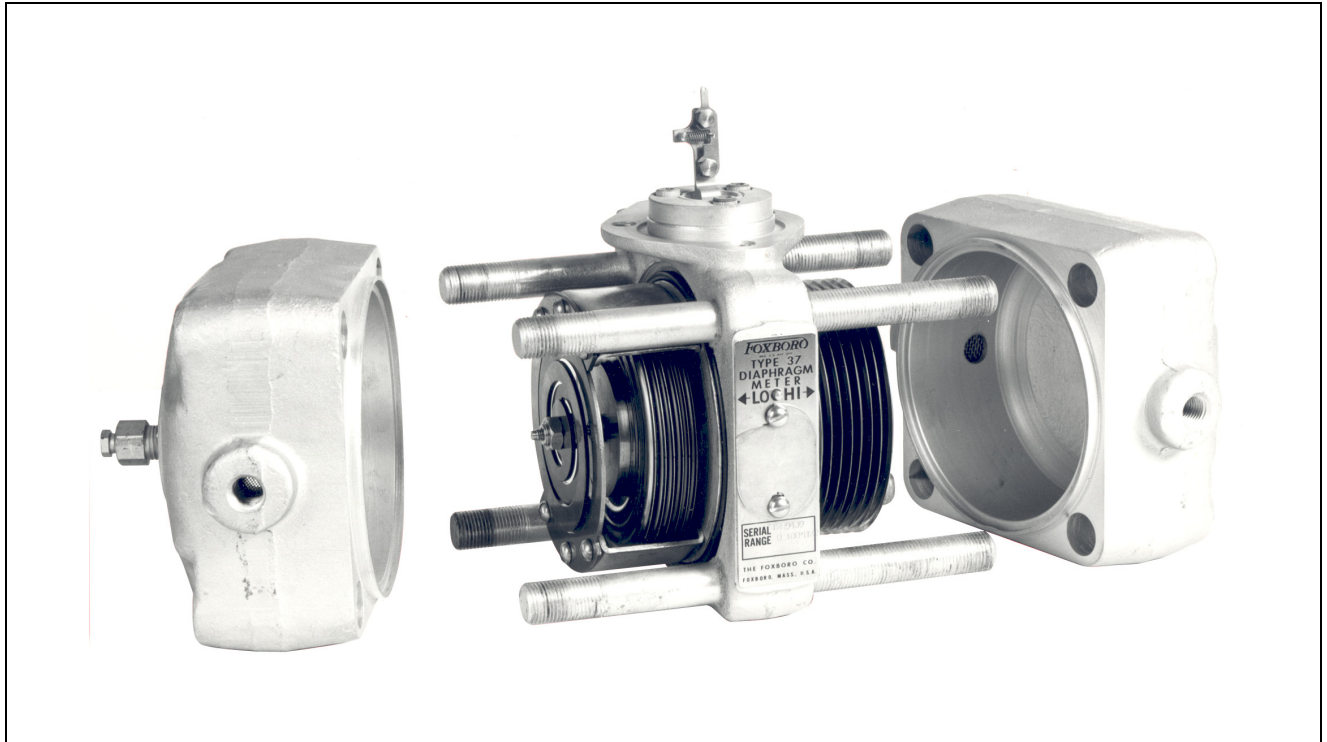

The Type 37 Diaphragm Measuring Element provides an accurate means of sensing differential pressure, whether produced by a primary device in measuring flow, by difference in liquid level within a vessel, or by pressures from two different sources. This element translates differential pressure to angular shaft position. It can be mounted to selected instruments to indicate, record, or actuate transmitter and control mechanisms.

MANY APPLICATIONS – EXCELLENT PERFORMANCE

The Type 37 measuring elements are used in a variety of liquid gas, and vapor flow applications, and liquid level head and differential pressure applications. They are particularly suited for wet gas measurement because of a self-draining feature. Because no mercury is used in the element, there is no need for precise leveling. These mercuryless elements have an inherent stability and excellent accuracy.

WIDE SELECTION OF CALIBRATION RANGES AND SPANS

Differential pressure (ΔP) calibration ranges are available between 0 to 5 and 0 to 50 kPa, 0 to 20 and 0 to 200 inH₂O, and 0 to 50 and 0 to 500 mbar. Zero differential pressure can be elevated (compound range) so that the lower range value is as low as minus 50% of span; or suppressed so that the upper range value is as high as either 150% of span, or 50 kPa (200 inH₂O, or 500 mbar), whichever is less.

PRECISION MOTION TRANSFER

Smooth, low friction motion is transferred from the element by a simple drive bar pivoted on flexure strips of cobalt-nickel metal alloy. This drive bar is linked to the pen or pointer, and results in a crisp, direct linear transmission of differential pressure changes. No bearings or internal element linkages are present to absorb motion or power.

PRECISE EXTERNAL DAMPING ADJUSTMENT

Damping occurs when the area of passage between the two diaphragms is restricted. This is conveniently accomplished by turning the damping screw adjustment, located externally, at the top of the element. The damper is adjustable while the system (instrument and element) is in service and under pressure. It provides accurate control of instrument response, yet cannot damp out measurement completely.

OVERRANGE PROTECTION

Overrange to 14 MPa (2000 psi, 140 bar or kg/cm²) does not damage the differential pressure element, nor significantly affect calibration. This is because the diaphragms are equipped with spacer rings which are welded to the inner fold of each diaphragm section. These rings provide positive, solid stops if the element is subjected to overrange.

AMBIENT TEMPERATURE COMPENSATION

A bimetallic temperature compensator adjusts capacity of diaphragm assembly to accommodate changing volume of fill fluid. A power Ni-Span C™ alloy range spring assures temperature stable zero and span settings even when the ambient temperature changes for -35 to +110° C (-30 to +230° F). This double protection against ambient temperature effects means year round accuracy and stability.

PERFORMANCE SPECIFICATIONS

Under Reference Operating Conditions

Upper Range Differential Pressure Values from			Performance in Percent of Upper Range Value(a)		
kPa	inH ₂ O	mbar	Accuracy	Repeatability	Dead Band
5 up to 12.5	20 up to 50	50 up to 125	±0.50	0.20	0.02
12.5 up to 25	50 up to 100	125 up to 250	±0.50	0.15	0.02
25 up to 50	100 up to 200	250 up to 500	±0.25(b)	0.10	0.02

(a)Performance stated is from input to pen or pointer, under reference operating conditions, and for zero-based ranges. Performance values for suppressed- and elevated-zero ranges are in percent of span.

(b)Accuracy is ±0.50% when concentric scale indicator is used.

MODEL CODE

Description	Model
Type 37 Diaphragm Measuring Element	DE
Body and Cover Material	
Zinc-cobalt carbon steel, ASTM Type A105	-A
Stainless steel, ASTM Type A182, Grade F316	-B
Example: DE-A	

(a)Upper range values less than 12.5 kPa (50 inH₂O, 125 mbar) should not be used with concentric scale indicators. Upper range values less than 12.5 kPa (50 inH₂O, 125 mbar) should not be used with Type 70 Electrical Contacts.

FUNCTIONAL SPECIFICATIONS

Ambient Temperature Limits

–35 and +110° C (–30 to +230° F)

Maximum Process Pressure

14 MPa (2000 psi, 140 bar or kg/cm²)

Pressure Safety

These elements are designed to provide safety for personnel when momentarily over pressurized to 1.5 times the maximum rated process pressure. No instrument degradation takes place when instruments are subjected to this pressure for periods up to 1 minute.

Standard Differential Pressure Ranges

Refer to Model Code.

Elevated- or Suppressed-Zero Ranges

Refer to Optional Calibration Section.

Spans

Available between 5 and 50 kPa, 20 and 200 inH₂O, or 50 and 500 mbar. For spans calibrated to desired value using a specific range spring, or a combination of range springs, refer to MI 005-553 or MI 005-554.

Application

The Type 37 element can be used with the 40M and 40P Series Recorders, Indicators, and Controllers; the 43AP Series Indicating Controllers; and the 45P Series Indicating Transmitters. When mounted to plastic case instruments, the Type 37 element is attached to an internal metal back-up plate located on the inside rear surface of the plastic case. Typically, one Type 37 element is used per instrument. However, a special yoke and instrument case mounting bracket is available for mounting two Type 37 elements with the 40M Series instruments. Additional, other pressure and temperature elements may be used with the Type 37 element to form a combination instrument, consistent with the space and operational limitations of that instrument. An intermediate linkage is used with all instruments.

Torque Factor

Instruments are assembled from a group of components. For a particular instrument, it is necessary to determine that the measuring element provides sufficient torque to operate the instrument components.

Invensys Foxboro has determined the torque capability of the measuring element, and the torque requirements of specific instrument components, using a relative term identified as the torque factor. The following is a graph of torque factor versus upper range value for the Type 37 element having

zero-based ranges. The different curves plotted represent the different range spring sets used within the element. Refer to Instrument Component Torque Factors for requirements. The instrument component torque factors are totaled and this total must not exceed the element torque factor. A Type 37 element torque factor rating greater than the required instrument torque factor provides a proportionately better instrument accuracy.

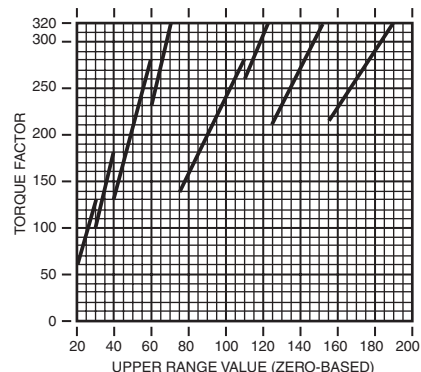

Instrument Component Torque Factors

Instrument Component	Torque Factor
Pen or Pointer Mechanism (Recorders or Indicators):	
Recording Pen	30
Sector Scale Indicating Pointer	30
Concentric Scale Indicating Pointer	150
40M or 40P Series Pneumatic Controllers(a):	
Single Component	20
43AP Series Pneumatic Controllers:	
Complete Instrument	30
45P Series Transmitters:	
Transmitter Mechanism	20
Type 70 Electric Contacts:	
Single Setting:	
3 Contacts	25
5 Contacts	40
7 Contacts	60
Double Setting:	
3 + 3 Contacts	70
5 + 5 Contacts	90
7 + 7 Contacts	105
Triple Setting:	
3 + 3 + 3 Contacts	105
5 + 5 + 5 Contacts	115
7 + 7 + 7 Contacts	130
Explosionproof:	
Single Setting (3 Contacts)	130
Single Setting (5 Contacts)	145
Single Setting (7 Contacts)	165

(a) Only one controller can be used with Type 37.

PHYSICAL SPECIFICATIONS

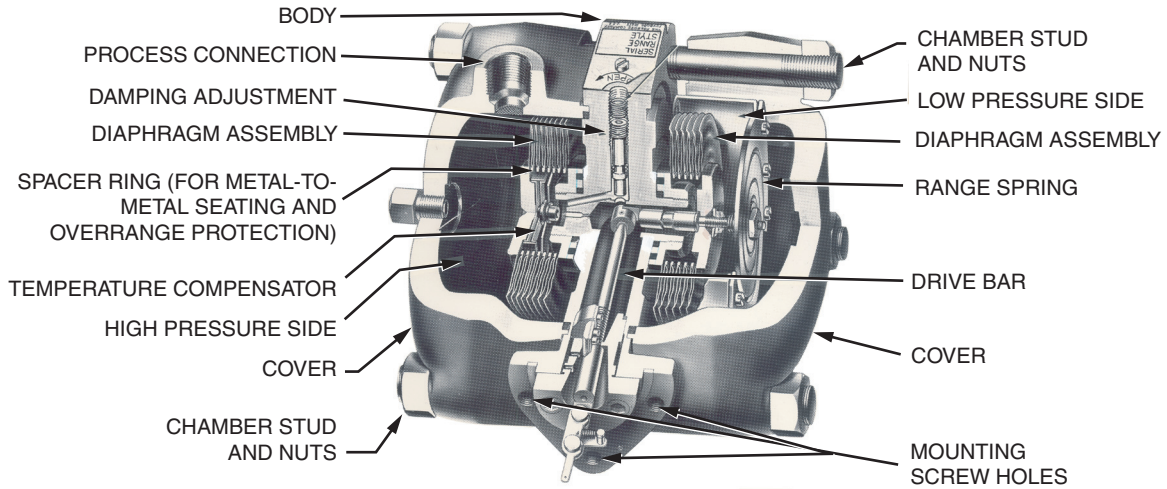

Figure 1. Type 37 Element

Mounting

Instrument or yoke mounting brackets are attached to the side of the element body using three 0.375-16 UNC-2B screws. The element is mounted to a nominal DN 50 or 2 in pipe stub using either the yoke mounting bracket, or a set of pipe-stub mounting parts.

Process Connections

Two process connections are available, one for the high pressure side, and one for the low pressure side of the element. These connections are tapped for either 1/4 NPT or 1/2 NPT, and are located on either the top or bottom of the element, as specified.

Body and Covers

Zinc-cobalt carbon steel (ASTM Type A105), or stainless steel (ASTM Type A182, Grade F136), as specified. Refer to Model Code.

Chamber Studs and Nuts

ASTM A193 Class B7 studs made from AISI Type 4140 steel with ASTM A914 Class 2H nuts.

Drive Bar Flexure

Cobalt-nickel alloy. Refer to Figure 2.

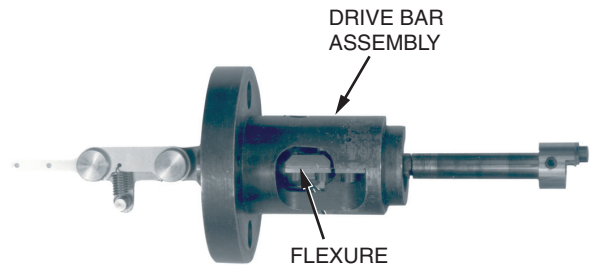

Figure 2. Drive Bar Flexure

Drive Bar Seal Bellows
(Free-Flexing) Nickel

Diaphragms
316 ss. Refer to Figure 3

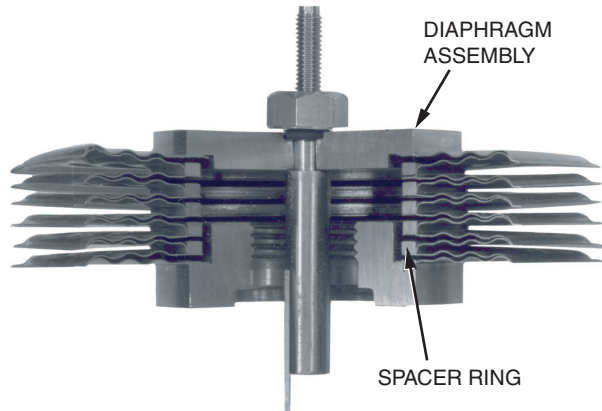

Figure 3. Diaphragm Assembly

PHYSICAL SPECIFICATIONS (CONT.)

Diaphragm Displacement

Span			Approximate Displacement	
kPa	inH ₂ O	mbar	cm ³	in ³
5	20	50	25	1.5
12.5	50	125	50	3.0
25	100	250	50	3.0
50	200	500	50	3.0

Ambient Temperature Compensator

Bimetallic cross unit, immersed in filling liquid. Refer to Figure 4.

HIGH EXPANSION SIDE

72% Mn, 18% Cu, 10% Ni

LOW EXPANSION SIDE

36% Ni, 64% Fe

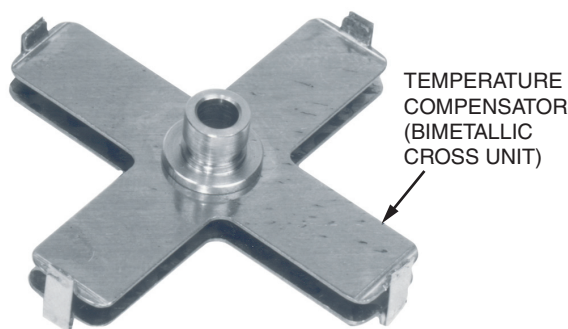

Figure 4. Temperature Compensator

Range Springs

Ni-Span C alloy. Refer to Figure 5.

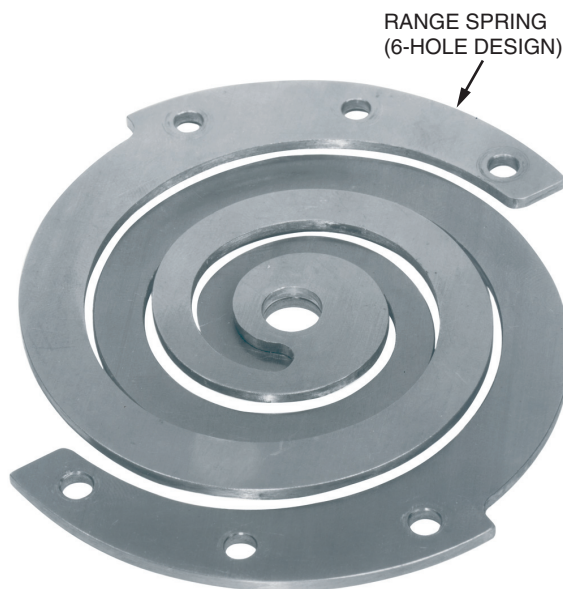

Figure 5. Range Spring

Element Gasket

Buna-N and Viton-A™ o-rings.

Element Fill Fluid

79% pure ethylene glycol, 21% water.

Approximate Mass

17 kg (37 lb), less fill fluid and mounting parts.

OPTIONAL FEATURES

Optional Calibrations

Specify calibration required in accordance with allowable zero-based, elevated-, or suppressed-zero ranges as required.

ZERO-BASED CALIBRATION

Any zero-based differential pressure range with upper range value between 5 and 50 kPa, 20 and 200 inH₂O, or 50 and 500 mbar ΔP.

SUPRESSED- OR ELEVATED-ZERO CALIBRATION

Suppressed-zero ranges whose upper range value is the less of 150% of span or 50 kPa (200 in H₂O, 500 mbar ΔP); and elevated-zero ranges whose lower range limit can be as low as -50% of span.

NACE

Special meter construction for compliance to NACE (National Association of Corrosion Engineers) Standard MR-01-75. All wetted parts designed to resist sulfide stress cracking in sour gas (H₂S) applications. AS Reference is MR-01

B7M Bolting

Same as NACE with additional B7M bolting. Required if external exposure of meter body to sour environments is anticipated. Body bolts and nuts conform to NACE Class II Standards. The maximum operating pressure is reduced to 10 MPa (1500 psi, 100 bar or kg/cm²). As Reference is MR-01-B7M.

ACCESSORIES

Bypass Manifolds

3- and 5-valve manifolds are in compliance with NACE requirements for gas, liquid, and vapor service. Manifold may be mounted below the instrument. For natural gas installations, based on AGA recommended practice, a double bypass and vent type manifold is standard. Additionally, block (shutoff) valves must be added close to the manifold and/or primary device. Specify type of service.

Description	Part Number
For Block (shutoff) and bypass manifold (3-valve) (Nace Compliance)	C0156CS
For double bypass and vent manifold (5-valve) (NACE compliance)	C0156CT
For block (shutoff) and bypass manifold (3-valve) (None NACE)	C0156CQ
For double bypass and vent manifold (5-valve) (None NACE)	C0156CR

Horizontal Condensing Chambers for Steam Service

Vent screw assembled in 1/4 NPT top connection. Piping connections tapped for 1/2 NPT. Condensing chambers good for steam pressure of 7 MPa (1000 psi, 70 bar or kg/cm²) absolute and line temperature of 510° C (950° F) if condensing chamber temperature does not exceed 260° C (500° F). Two required. Specify Part Number 0045776.

Flexible Connectors

For gas and liquid service. For use as impulse piping between primary device and manifold. Maximum pressure is 17 MPa (2500 psi, 170 bar or kg/cm²). Specify Part Number B0110EB for 1 m (3 ft) length. Specify Part Number B0110EC for 2 m (6 ft) length. Two required.

Metal Calibration Scale

Uniform differential pressure graduations of 20, 50, and 100 in. Provided in black pocket case. Specify Part Number 0021455.

Purge Rotameter

With 1/4 NPT connection. For gas and liquid service. A combination control valve (adjustable restrictor) and visual indicator of flow, with check valve in the outlet to prevent reverse flow. Available in many flow rate ranges for both SI and customary units. Specify flow rate and scale markings required. Two required.

Differential Pressure Regulator

With 1/4 NPT connection. Supply pressure to 1.7 MPa (250 psi, 17 bar or kg/cm²). Differential pressure 20 kPa (3 psi, 0.2 bar or kg/cm²). Specify part Number B0107XX.

Steel Union with Restricting Orifice

With 1/4 NPT connection. For liquid applications. Maximum working pressure is 10 MPa (1500 psi, 100 bar or kg/cm²). Two required, for liquid applications. Specify Part Number 0039945.

ORDERING INSTRUCTIONS

1. Model Number (refer to Model Code)
2. Differential Pressure Range
3. Optional Features and Accessories
4. Associated Primary Device
5. Tag and Application

OTHER M&I PRODUCTS

Invensys Foxboro provides a broad range of measurement and instrument products, including solutions for pressure, flow, analytical, positioners, temperature, controlling and recording. For a listing of these offerings, visit the Invensys Foxboro web site at:

www.foxboro.com/m&i

DIMENSIONS – NOMINAL

$\frac{\text{mm}}{\text{in}}$

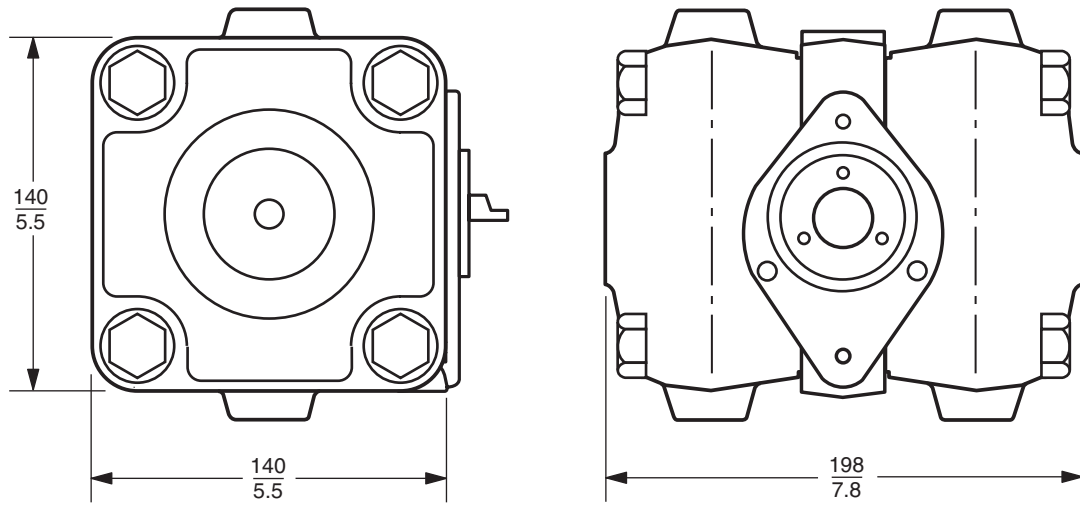

33 Commercial Street
Foxboro, MA 02035-2099
United States of America

www.foxboro.com
Inside U.S.: 1-866-746-6477
Outside U.S.: 1-508-549-2424
or contact your local Foxboro
representative.
Facsimile: 1-508-549-4999

Invensys and Foxboro are trademarks of Invensys plc, its subsidiaries, and affiliates.
All other brand names may be trademarks of their respective owners.

Copyright 1981-2003 Invensys Systems, Inc.
All rights reserved

MB 010

Printed in U.S.A.

0403