

Model IMV25 I/A Series® Multivariable Transmitters for Pressure, Differential Pressure, and Temperature Measurements with HART® Communication Protocol

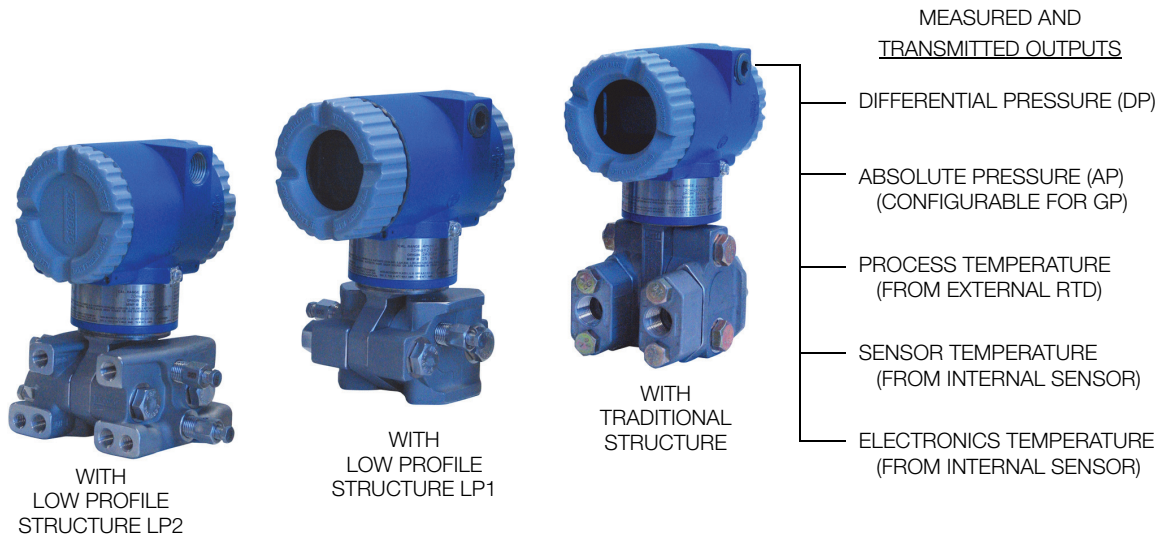

This intelligent two-wire, multivariable transmitter provides precise and reliable measurement of pressure, differential pressure, sensor and electronics temperatures, and process temperature (from an external RTD). It transmits a 4 to 20 mA or digital output signal, as applicable, using HART communication protocol for remote configuration, calibration, and monitoring.

FEATURES

- ▶ One transmitter for many applications
 - Individual measurements on a 2-wire loop
 - Multiple measurements digitally
 - Assigns 4 to 20 mA to any measurement.
- ▶ Select a transmitter with traditional or low profile structures.
- ▶ HART for remote communication. Convenient module change allows migration between protocols.
- ▶ Remote configuration using a host or Model PCMV PC-based configurator.
- ▶ Local configuration available with the optional LCD indicator with on-board pushbuttons.
- ▶ Reduced process penetrations save money and reduce chances of fugitive emissions.
- ▶ One transmitter replaces three separate transmitters - means less wiring, fewer shutoff valves, and reduced installation costs.
- ▶ Greater reliability due to fewer devices and less wiring means less chance of losses from downtime or process upsets.
- ▶ High functionality and high performance provide exceptional value.
- ▶ Durable aluminum or 316 ss housing available; both meet NEMA 4X and IEC IP66.
- ▶ Complies with NAMUR NE 21 Interference Immunity requirement, and NAMUR 105 overrange and underrange annunciations.
- ▶ CE marked; complies with EMC, ATEX, and PED European Directives.

- ▶ Designed for hazardous area installations; versions available to meet agency flameproof and zone requirements.
- ▶ Optional standard and universal style mounting bracket sets allow installation flexibility.
- ▶ Numerous other options and accessories expand the capabilities of these transmitters.
- ▶ Standard 5-year warranty.

I/A SERIES PRESSURE TRANSMITTER FAMILY

The I/A Series Electronic Pressure Transmitters are a complete family of d/p Cell[®], gauge, absolute, multirange, multivariable, and premium performance transmitters, as well as transmitters with remote or direct connect seals, all using field-proven silicon strain gauge sensors and common topworks.

EXCEPTIONALLY HIGH PERFORMANCE

- ▶ Accuracy to $\pm 0.05\%$ of span
- ▶ Long term stability is excellent as drift is less than $\pm 0.05\%$ of URL per year over a 5-year period for both DP and P measurements
- ▶ Minimized static pressure effect on DP by using pressure to compensate the dp measurement
- ▶ Excellent ambient temperature effect compensation due to characterization and microprocessor-based compensation
- ▶ Total Probable Error (TPE) significantly better than typical competitive transmitters.

SENSOR CORROSION PROTECTION

Industry standard 316L ss and nickel alloy (equivalent to Hastelloy[®] C⁽¹⁾) sensor materials are provided for corrosion protection. Refer to TI 37-75b for process applicability with these wetted parts.

EASE OF INSTALLATION

- ▶ Rotatable Topworks
 - Allows installation in tight places
 - Positions indicator in preferred direction
 - Eases field retrofit
- ▶ Two Conduit Connections
 - Provide for easy wiring
 - Allow self-draining of condensation
- ▶ Wiring Guides and Terminations
 - Provide easy wire entry and plenty of space
 - Use large, rugged screw terminals for easy wire termination.

PROCESS CONNECTORS

Removable, gasketed connectors allow a wide range of selections, including 1/4 NPT, 1/2 NPT, Rc 1/4, Rc 1/2, and weld neck connectors.

FLAMEPROOF AND EXPLOSIONPROOF DESIGN

Transmitter meets numerous agency requirements for hazardous area locations. Versions available to meet agency flameproof and zone requirements.

DIGITAL AND 4 TO 20 mA OUTPUT

The IMV25 provides 4 to 20 mA and digital output using the HART communication protocol.

Digital HART and 4 to 20 mA dc (Version -T Electronics)

4 to 20 mA with HART communications allows direct analog connection to common receivers while still providing full Intelligent Transmitter Digital Communications using a HART Communicator or Model PCMV Configurator.

Users having HART Communicators for other devices can have them upgraded with Invensys software to accommodate these transmitters. Also, Invensys will make use of the HART Foundation library of registered DDs (Device Descriptors), and reload the Communicator if the user desires to keep another supplier's DD along with the Foxboro[®] DD.

(1) Hastelloy is a registered trademark of Haynes International, Inc.

ANALOG OR DIGITAL TRANSMISSION

- ▶ When configured for analog output, the 4 to 20 mA Output can be assigned to any one of the following variables:
 - Differential Pressure
 - Absolute Pressure
 - Process Temperature
 - Sensor Temperature
 - Electronics Temperature

Also, these variables can be read digitally using a remote configurator, even though the transmitter is configured for a 4 to 20 mA output.

- ▶ When configured for digital output, any three of the five variables listed above can be selected for remote communication with HART Communicator or Model PCMV PC-based Configurator.

MODEL PCMV CONFIGURATOR

This Windows-based software package displays measurements and has full calibration and configuration capability. See PSS 2A-1Z3 F for applications using the Model PCMV configurator with the Model IMV25 Transmitter.

OPTIONAL LCD DIGITAL INDICATOR

- ▶ A digital indicator with on-board pushbuttons is available to display the measurement with a choice of units.
- ▶ The pushbuttons allow zero and span adjustments, as well as routine local configuration changes.

TYPICAL INSTALLATION TOPOLOGIES

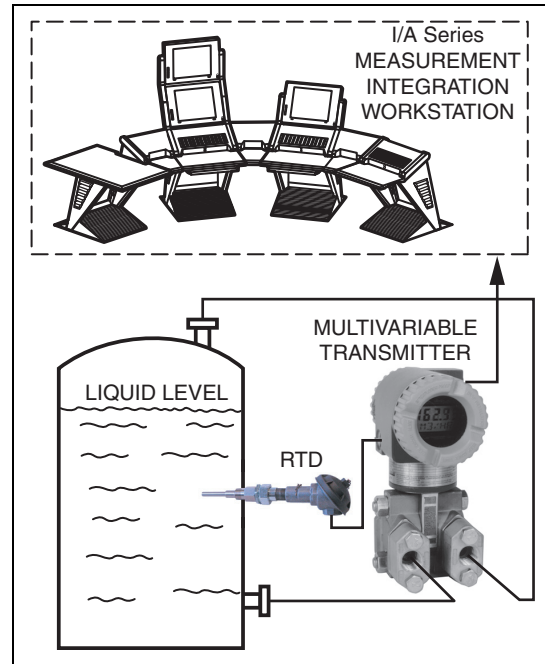

Figure 1. Typical Application for Liquid Level Measurement

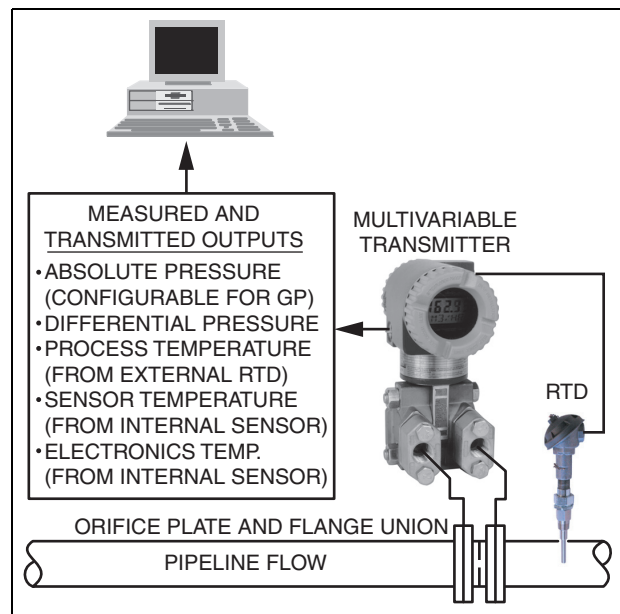

Figure 2. Typical Application for Flow Rate Measurement

COMPLIANCE WITH EUROPEAN UNION DIRECTIVES

- ▶ Complies with Electromagnetic Compatibility Requirements of European EMC Directive 89/336/EEC by conforming to the following CENELEC and IEC Standards: EN 50081-2, EN 50082-2, and IEC 61000-4-2 through 61000-4-6.
- ▶ Complies with NAMUR NE 21 Interference Immunity Requirement, and NAMUR 105 overrange and underrange annunciations.
- ▶ Complies with NAMUR 105 overrange and underrange annunciations.
- ▶ Complies with all applicable European Union Directives (“CE” Logo marked on product).

UNIQUE PROCESS COVER AND CELL BODY DESIGN

Biplanar Construction (Figure 3) maintains the traditional horizontal process connections and vertical mounting by providing a cell body contained between two process covers, while still achieving light weight, small size, and high static pressure rating. This provides easy retrofit of any conventional differential pressure transmitter, and also is easily mounted in the horizontal position with vertical process connections, when required.

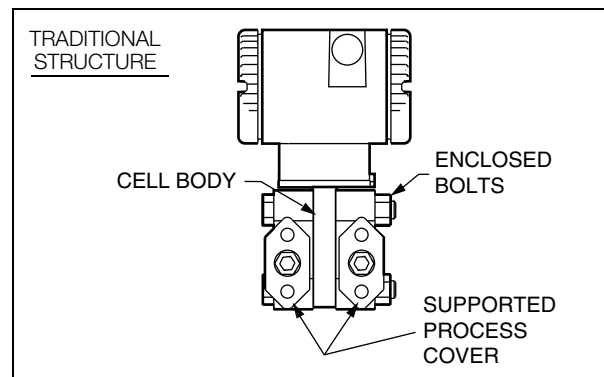

Figure 3. Biplanar Construction Shown with Traditional Horizontal Process Connections

Process Covers (Figure 3) are fully supported by the cell body over their entire height. This prevents bending and results in a highly reliable seal. Also, this provides dimensional stability to the process covers, ensuring that they will always mate properly with 3-valve bypass manifolds.

Process Cover Bolts (Figure 3) are enclosed to minimize corrosion and to minimize early elongation with rapid temperature increases. The design makes it less likely for the transmitter to release process liquid during a fire.

Process Cover Gaskets are ptfе as standard; ptfе provides nearly universal corrosion resistance, and eliminates the need to select and stock various elastomers to assure process compatibility.

Light Weight provides ease of handling, installation, and direct mounting without requiring costly pipe stands.

TRANSMITTER STRUCTURES

Traditional and low profile structures (LP1 and LP2) are offered to accommodate and to provide flexibility in transmitter installations. See paragraphs below.

Traditional Structure

The traditional structure (Figure 4) utilizes the right angle design common to most DP transmitters in use throughout the world. Process connections are oriented 90 degrees from the transmitter centerline.

This traditional structure makes it easy to retrofit any transmitters of similar design.

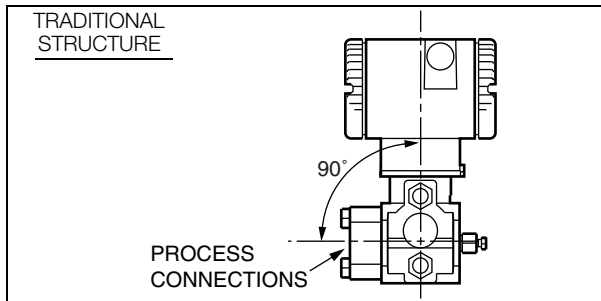

Figure 4. Vertical Mounting Showing Process Connections at 90 degrees

Sensor cavity venting and draining is provided for both vertical and horizontal transmitter installation, using innovative tangential connections to the sensor cavity (Figures 5 and 6). Optional side vents are offered for sensor cavity venting in the upright position (Figure 7).

An extensive variety of process-wetted materials are available for the process covers on this highly versatile and widely used transmitter.

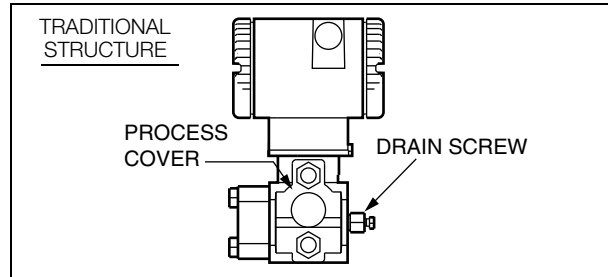

Figure 5. Vertical Mounting - Cavity Draining

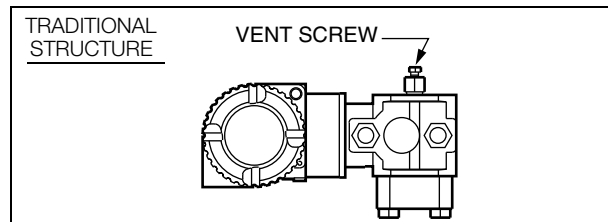

Figure 6. Horizontal Mounting - Cavity Venting and Self-Draining into Process Line

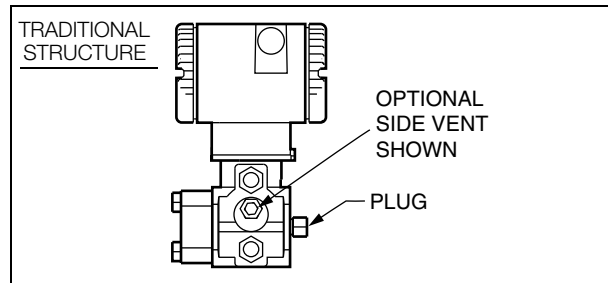

Figure 7. Vertical Mounting - Cavity Venting and Self-Draining into Process Line

Low Profile Structures

The low profile structures utilize an in-line design, placing the process connections in line with the transmitter centerline (Figure 8). This allows mounting of the transmitter in the upright position with the process connections facing downward, for connection to vertical process piping or for mounting directly to a three- or five-valve manifold (Figure 9).

The low profile structures provide a mounting style similar to that used by competitive Coplanar™ transmitters. This makes it easy to select Foxboro transmitters for both retrofit and new applications where this type of installation is desired.

Transmitters with the low profile structure can be attached directly to existing, installed Coplanar manifolds, such as the Rosemount Model 305RC or Anderson Greenwood Models MB3, MB5G, and MB5P, by use of an optional adapter plate (see Figure 10). Also, when assembled to the same process piping or manifold as a Coplanar transmitter, one of the electrical conduit connections is located within ± one inch of the similar conduit connection on the competitive transmitter, assuring ease of retrofit or conformance with installation design drawings.

All parts making up the low profile versions are identical to the parts in the traditional version except for the process covers and the external shape of the sensor cell body.

For user convenience, two types of low profile structures are offered, type LP1 and LP2. The process covers are the only transmitter parts that differ between structure types LP1 and LP2.

Refer to the sections that follow for further descriptions of low profile structures LP1 and LP2.

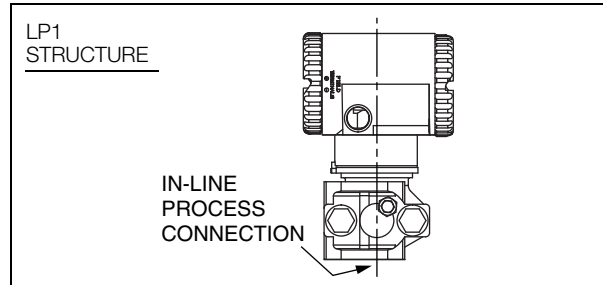

Figure 8. Low Profile Structure - LP1 Shown

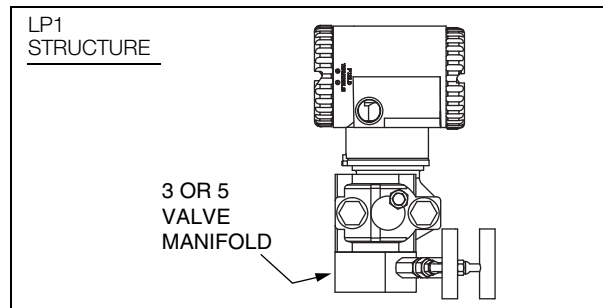

Figure 9. LP1 Shown Directly Mounted to Manifold

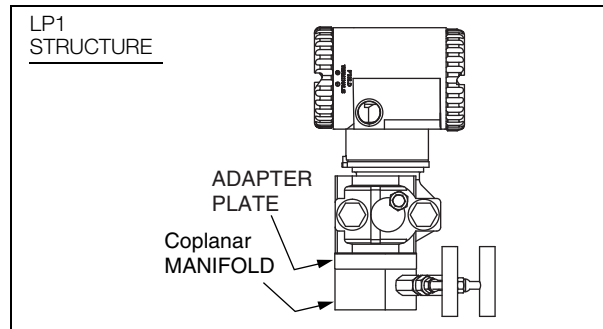

Figure 10. LP1 Shown Mounted to a Coplanar Manifold using an Optional Intermediate Adapter Plate

Low Profile Structure LP1 – Direct Mount

Structure LP1 is a compact, inexpensive, lightweight design for direct mounting to a separately mounted manifold or process piping. These transmitters are not typically bracket-mounted.

They are supplied as standard with a single vent/drain screw in the side of each process cover. In conjunction with the standard tangential venting and draining design, they are suitable for mounting either vertically (Figure 11) or horizontally, and are suitable for nearly all applications, including liquids, gases, and steam. For horizontal installation, they can simply be “turned over” (rotated 180 degrees - Figures 12 and 13) to orient the high and low pressure sides in the preferred locations. There is no need to unbolt process covers. The topworks housing can also be rotated, as shown, to orient the conduit connections in the desired position.

In the vertical, upright position, they are also self-draining and are ideal for gas flow rate service, when directly mounted to a manifold located above the horizontal pipeline. The vent screw can be omitted for this or other applications, if desired.

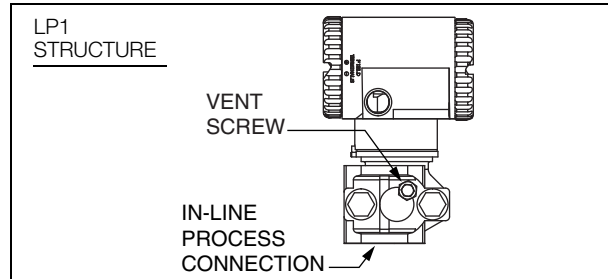

Figure 11. Upright Mounting

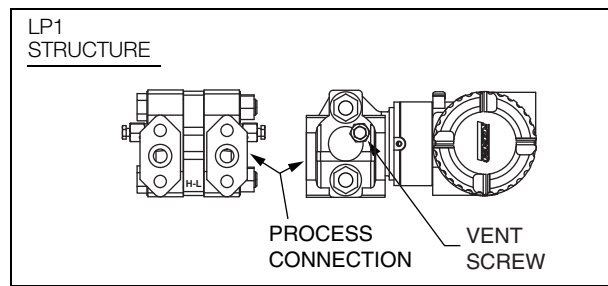

Figure 12. Horizontal Mounting with Vent Screw

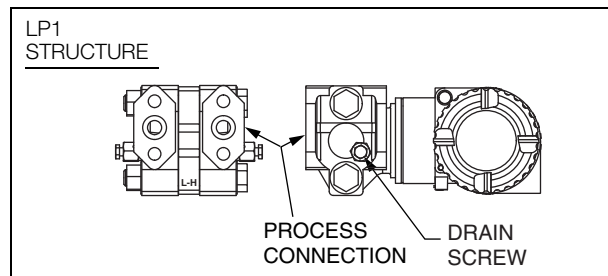

Figure 13. Horizontal Mounting with Drain Screw

Low Profile Structure LP2 - Bracket or Direct Mount

Structure LP2 is a universal design for either bracket or direct mounting. Drilled and tapped mounting holes facilitate mounting to either new or existing Foxboro brackets (Options -M1, -M2, and -M3), as well as standard brackets supplied with existing Coplanar transmitters (Figures 14 and 15).

These transmitters can also be directly mounted to manifolds or process piping and are available with the same optional adapter used with low profile structure LP1 to fit existing Coplanar manifolds (Figure 16).

For extra convenience, they use a full-featured vent and drain design, with separate vent and drain screws positioned in each cover for complete venting or draining directly from the sensor cavity. They are normally recommended for upright, vertical installation.

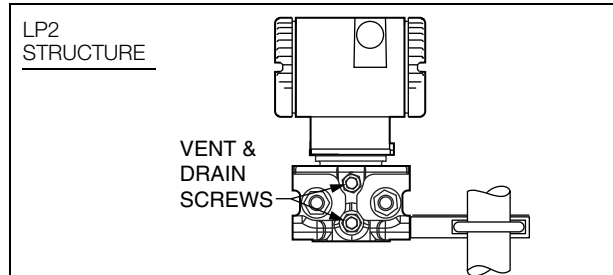

Figure 14. Shown on Foxboro Universal Bracket

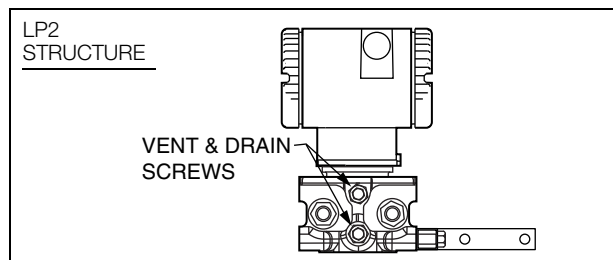

Figure 15. Shown on Coplanar Bracket

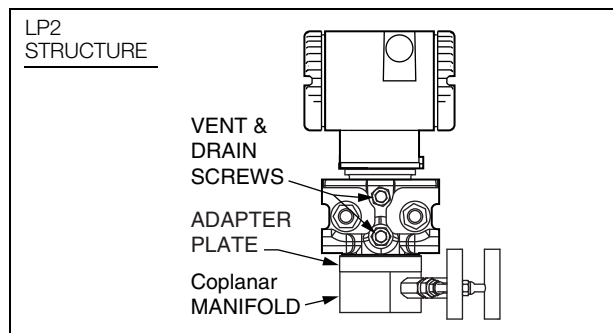

Figure 16. Adapter Mount to Existing Coplanar Manifold

FUNCTIONAL SPECIFICATIONS

Span and Range Limits for Differential Pressure Measurement

Span Code (a)	Span Limits			Range Limits (b)		
	kPa	inH ₂ O	mbar	kPa	inH ₂ O	mbar
L	0.12 and 2.5	0.5 and 10	1.2 and 25	-2.5 and +2.5	-10 and +10	-25 and +25
A	0.75 and 7.5	3 and 30	7.5 and 75	-7.5 and +7.5	-30 and +30	-75 and +75
B	0.5 and 50	2 and 200	5 and 500	-50 and +50	-200 and +200	-500 and +500
C	2.5 and 210	10 and 840	25 and 2100	-210 and +210	-840 and +840	-2100 and +2100

(a) See maximum static, working, and range limits table below for available combinations of DP and AP span codes.

(b) Positive values indicate HI side of sensor at the high pressure, and negative values indicate LO side of sensor at the high pressure.

Span and Range Limits for Absolute Pressure Measurement (a)

Span Code (b)	Span Limits			Range Limits		
	MPa	psia	bar or kg/cm ²	MPaa	psia	bara or kg/cm ² abs.
D	0.02 and 2.1	3 and 300	0.21 and 21	0 and 2.1	0 and 300	0 and 21
G	0.07 and 3.5	10 and 500	0.7 and 35	0 and 3.5	0 and 500	0 and 35
E	0.21 and 10	30 and 1500	2.1 and 100	0 and 10	0 and 1500	0 and 100
H	0.42 and 20	60 and 3000	4.2 and 200	0 and 20	0 and 3000	0 and 200
F	3.4 and 36.5	500 and 5300	34 and 365	0 and 36.5	0 and 5300	0 and 365

(a) Absolute Pressure measured directly; Gauge Pressure calculated from user-entered barometric pressure constant.

(b) See maximum static, working, and range limits table below for available combinations of DP and AP span codes.

Sensor URL, Maximum Static Pressure and Working Pressure and Maximum Overrange Pressure

Allowable Span Code Combinations DP and AP	Sensor URL (DP and AP)				Maximum Static and Maximum Working Pressure (MWP)		Maximum Overrange Pressure	
	DP	AP	DP	AP	MPaa	psia	MPaa	psia
L and G	10 inH ₂ O	500 psia	2.5 kPa	3.4 MPaa	3.4	500	5.2	750
A and G	30 inH ₂ O	500 psia	7.5 kPa	3.4 MPaa	3.4	500	5.2	750
B and D	200 inH ₂ O	300 psia	50 kPa	2.1 MPaa	2.1	300	3.1	450
B and E	200 inH ₂ O	1500 psia	50 kPa	10 MPaa	10	1500	15	2250
B and H	200 inH ₂ O	3000 psia	50 kPa	20 MPaa	20	3000	30	4500
B and F	200 inH ₂ O	5300 psia	50 kPa	36.5 MPaa	36.5	5300	51.2	7420
C and D	840 inH ₂ O	300 psia	210 kPa	2.1 MPaa	2.1	300	3.1	450
C and E	840 inH ₂ O	1500 psia	210 kPa	10 MPaa	10	1500	15	2250
C and H	840 inH ₂ O	3000 psia	210 kPa	20 MPaa	20	3000	30	4500
C and F	840 inH ₂ O	5300 psia	210 kPa	36.5 MPaa	36.5	5300	51.2	7420

Impact of Certain Options on Maximum Static Pressure and Span and Range Limits (a) (b)

Option	Description (Also see Model Code)	Span and Range Limits Derated to:
-B3	B7M Bolts and Nuts (NACE)	20 MPaa (2900 psia, 200 bara or kg/cm ² abs)
-D1	DIN Construction	16 MPaa (2320 psia, 160 bara or kg/cm ² abs)
-D5 or -B1	DIN Construction or 316 ss Bolting	15 MPaa (2175 psia, 150 bara or kg/cm ² abs)
-D2, -D4, -D6, or -D8	DIN Construction	10 MPaa (1500 psia, 100 bara or kg/cm ² abs)

- (a) Refer to Model Code section for application and restrictions related to the items listed in the table.
- (b) There is no impact (derating) when Options -B2, -D3, or -D7 are selected. The ratings for these options are the standard rating of 25 MPaa (3625 psia, 250 bara, or kg/cm² abs).

Output Signal and Configuration

4 to 20 mA with HART Communications. When configured for multidrop applications, the mA signal is fixed at 4 mA to provide power to the device. Configurable using a HART Communicator, Model PCMV Configurator, or optional LCD indicator with on-board pushbuttons.

Measured and Transmitted Outputs

- ▶ Absolute Pressure/AP (Configurable for GP)
- ▶ Differential Pressure/DP
- ▶ Sensor Temperature
- ▶ Electronics Temperature
- ▶ Process Temperature (from External RTD)

Process Temperature Measurement and Limits

- ▶ Measurement: DIN/IEC, 2-, 3-, or 4-wire, 100 Ω, Platinum RTD
- ▶ Range Limits: -200 and +850°C (-328 and +1562°F)

Zeroing for Nonzero-Based Ranges

Dual Function Zeroing from the optional LCD indicator pushbuttons allows differential pressure zeroing with either zero differential or LRV differential applied. This greatly simplifies position effect zeroing on many pressure and level applications. The Model PCMV Configurator, HART Communicator, or optional LCD indicator with pushbuttons provide zeroing at any user-entered value.

Zero and Span Adjustments

Zero and span adjustments can be initiated from any of the following: I/A Series Workstation (with applicable FBMs), the HART Communicator, a Model PCMV PC-based configurator, or the optional LCD indicator with on-board pushbuttons.

Suppressed Zero and Elevated Zero

Suppressed or elevated zero ranges acceptable as long as Span and Range Limits are not exceeded.

Write Protect Jumper

Can be positioned to lock out all configurators from making transmitter database changes. This makes transmitter suitable for Safety Shutdown System Applications that require this feature.

Current Outputs for Overrange, Fail, and Offline Conditions

Parameter	HART
OFFLINE	User configurable between 4 and 20 mA
SENSOR FAILURE	User configurable to Fail LO or Fail HI
FAIL LO	3.60 mA
UNDERRANGE	3.80 mA
OVERRANGE	20.50 mA
FAIL HI	21.00 mA

FUNCTIONAL SPECIFICATIONS

Square Root Low Flow Cutoff

User configurable to provide:

- ▶ Cutoff to Zero at Flows < 10% of Maximum Flow (1% of Maximum Differential Pressure).
- ▶ Or Active Point-to-Point Line between Zero and 20% of Maximum Flow (4% of Maximum Differential Pressure).
- ▶ Flow Cutoff in Engineering Units (Fieldbus Only)

Adjustable Damping (DP and Pressure)

The transmitter response time is normally 1.0 s, or the electronically adjustable setting of 0.00 (none), 0.25, 0.50, 1, 2, 4, 8, 16, or 32 seconds, whichever is greater, for a 90% recovery from an 80% input step as defined in ANSI/ISA S51.1.

Field Wiring Reversal

No transmitter damage.

Configuration and Calibration Data, and Electronics Upgradeability

All factory characterization data, and user configuration and calibration data, are stored in the sensor. This means that the electronics module can be replaced or changed from one type to another.

A module may be replaced without the need for reconfiguration or recalibration. Although module replacement can affect accuracy up to 0.20% of span, this error can be removed by an mA trim without application of pressure.

Changing module types may require reconfiguration and recalibration, but all factory characterization data is retained.

Configuration Capability (a)

Variable	Measurement
Primary Variable	Differential Pressure (DP)
Secondary Variable	Absolute Pressure (AP)
Tertiary Variable	Process Temperature

(a) Numerous parameters can be configured and/or displayed, such as electronic damping, failsafe direction, transmitter calibration, tag data, etc. See applicable configuration documents for details.

Supply Voltage

- ▶ **Digital Output:** Bidirectional digital signal superimposed on the 4 to 20 mA current signal.
- ▶ **4 to 20 mA:** Minimum supply voltage shown in Figure 17 is 11.5 V dc. This can be reduced to 11 V dc by using a plug-in jumper across the test receptacles in the field wiring compartment terminal block. Invensys offers an optional plug-in shorting bar (SB-11) for this purpose.

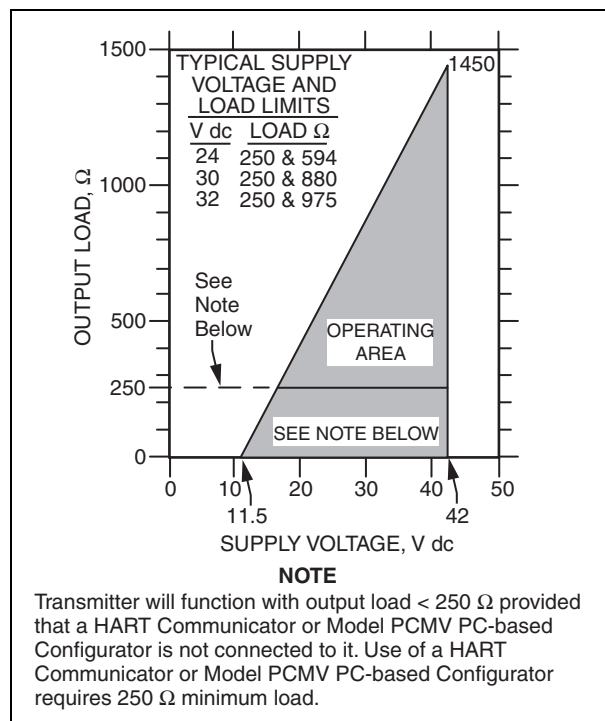

Figure 17. 4 to 20 mA Output, Supply Voltage vs. Output Load

Minimum Allowable Absolute Pressure vs. Transmitter Temperature

- ▶ **With Silicone Fill Fluid**
Full vacuum: up to 121 °C (250 °F).
- ▶ **With Fluorinert Fill Fluid**
Refer to Figure 18.

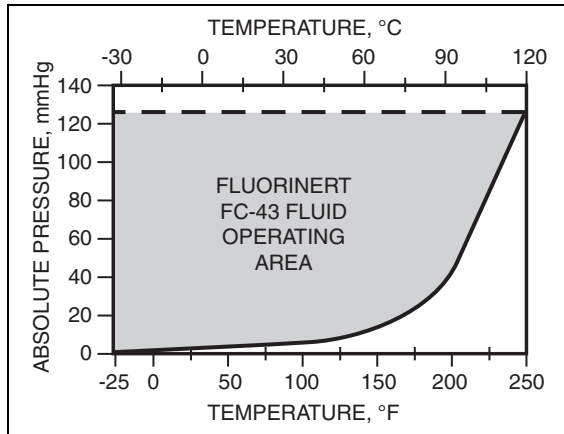

Figure 18. Minimum Allowable Absolute Pressure vs. Transmitter Temperature, Fluorinert FC-43, 2.6 cs at 25°C (77°F)

Available Units for Calibrated Range

Pressure					Temp.
inH ₂ O	inHg	Pa	torr	g/cm ²	C
ftH ₂ O	mmHg	kPa	mbar	kg/cm ²	F
mmH ₂ O		MPa	bar	psi	R
mH ₂ O				atm	K

Optional Custom Configuration (Option -C2)

For the transmitter to be custom configured by the factory, the user must fill out a data form. If this option is not selected, a standard default configuration will be provided; for example:

Parameter	Standard (Default) Configuration	Example of Custom Configuration Option -C2
Measurement 1	Linear	Square Root
Device Name	DevNam	FT103A
External Zero	Enabled	Disabled
EGU	inH ₂ O	%
Damping	None	0.5 s

HART (Version -T) Communications

- ▶ **4 to 20 mA Analog Mode:** Analog output signal is updated 30 times per second. A minimum loop load of 250 ohms is required. See Table 1 for communication parameters, and Figure 20 for a typical functional block diagram.
- ▶ **Multidrop Mode (Fixed Current):** This mode supports communications with up to 15 transmitters on a single pair of signal/power wires. The output signal is updated 4 times/second. A minimum loop load of 250 ohms is required. See Table 1 for communication parameters and Figure 21 for a typical multidrop functional block diagram.

Optional LCD Indicator with On-Board Pushbuttons (Figure 19)

- ▶ Indicator provides:
 - Two lines; five numeric characters on top line (four when a minus sign is needed) and seven alphanumeric characters on bottom line.
 - Measurement readout; value on top line and units label on bottom line.
 - Configuration and calibration prompts.
- ▶ Two pushbuttons provide:
 - Configuration functions
 - Calibration functions

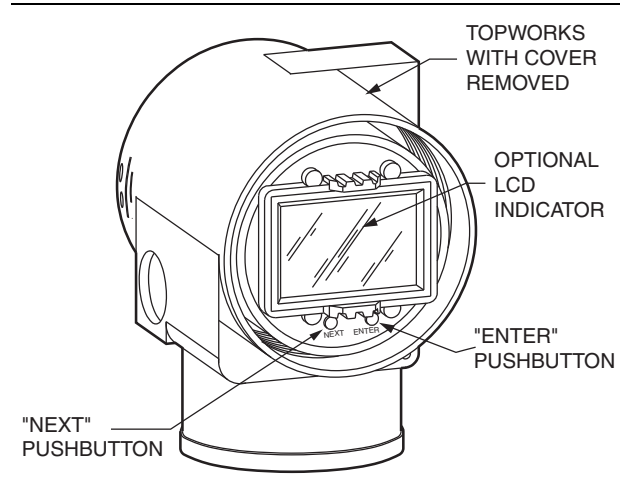

Figure 19. LCD Indicator with Pushbuttons

Table 1. Communication Parameters - HART

Parameter	HART	
	Analog Mode	Multidrop Mode
Remote Configurator	HART Communicator or Model PCMV Configurator	
Communication Rate	1200 baud	1200 baud
Communication Distance (Rated) (a)	3050 m (10 000 ft)	1525 m (5000 ft)

(a) Total cable length includes spur length. Maximum spur length is 120 m (395 ft). Minimum spur length is 1 m (3.3 ft). For intrinsically safe installations, maximum spur length is 30 m (98 ft).

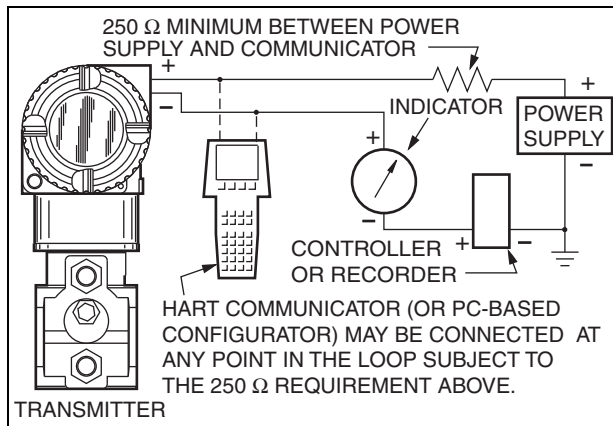

Figure 20. HART 4 to 20 mA Topology

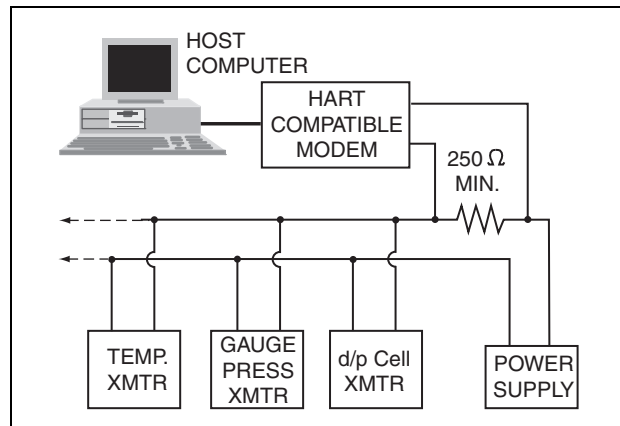

Figure 21. HART Multidrop Topology

OPERATING, STORAGE, AND TRANSPORTATION CONDITIONS

Influence	Reference Operating Conditions	Normal Operating Conditions (a) (b)	Operative Limits (a) (b)	Transportation/Storage Limits
Sensor Body Temperature ▶ w/Silicone Fill Fluid	24 ±2°C (75 ±3°F)	-29 to +82°C (-20 to +180°F)	-46 and +121°C (c) (-50 and +250°F) (c)	Not Applicable
▶ w/Fluorinert Fill Fluid	24 ±2°C (75 ±3°F)	-29 to +82°C (-20 to +180°F)	-29 and +121°C (-20 and +250°F)	Not Applicable
Electronics Temperature	24 ±2°C (75 ±3°F)	-29 to +82°C (e) (-20 to +180°F) (e)	-40 and +85°C (e) (-40 and +185°F) (e)	-54 and +85°C (-65 and +185°F)
▶ with LCD Indicator (d)	24 ±2°C (75 ±3°F)	-20 to +82°C (e) (-4 to +180°F) (e)	-29 and +85°C (e) (-20 and +185°F) (e)	-54 and +85°C (-65 and +185°F)
Relative Humidity (f)	50 ±10%	0 to 100%	0 and 100%	0 and 100% Noncondensing
Supply Voltage – mA Output HART	30 ±0.5 V dc	11.5 to 42 V dc (g)	11.5 and 42 V dc (g)	Not Applicable
Output Load – mA Output HART	650 Ω	0 to 1450 Ω (h)	0 and 1450 Ω (h)	Not Applicable
Vibration	1 m/s ² (0.1 “g”)	6.3 mm (0.25 in) Double Amplitude: from 5 to 15 Hz with Aluminum Housing from 5 to 9 Hz with 316 ss Housing 0 to 30 m/s ² (0 to 3 “g”) from 15 to 500 Hz with Aluminum Housing; 0 to 10 m/s ² (0 to 1 “g”) from 9 to 500 Hz with 316 ss Housing	11 m/s ² (1.1 “g”) from 2.5 to 5 Hz (in Shipping Package)	
Mounting Position	Upright or Horizontal (i)	Upright or Horizontal (i)	No Limit	Not Applicable

- (a) When DIN Construction Options -D2/-D4/-D6/-D8 are used, temperature limits are 0 and 60°C (32 and 140°F).
- (b) Normal Operating Conditions and Operative Limits are defined per ANSI/ISA 51.1-1979 (R1993).
- (c) Selection of Option -J extends the low temperature operative limit of transmitters with silicone-filled sensors down to -50°C (-58°F). Performance is not assured below -29°C. Sensor damage may occur if process is frozen.
- (d) Although the LCD will not be damaged at any temperature within the “Transportation/Storage Limits”, updates will be slowed and readability decreased at temperatures outside the “Normal Operating Conditions”.
- (e) Refer to the Electrical Safety Specifications section for a restriction in ambient temperature limits with certain electrical certifications.
- (f) With topworks cover on and conduit entrances sealed.
- (g) 11.5 V dc can be reduced to 11 V dc by using a plug-in shorting bar.
- (h) With HART, 250 Ω minimum load required for proper communication.
- (i) Sensor process wetted diaphragms in a vertical plane.

PERFORMANCE SPECIFICATIONS

PERFORMANCE SPECIFICATIONS

Zero-Based Calibrations; Stainless Steel Sensor with Silicone Fluid; Under Reference Operating Conditions unless otherwise specified; URL = Upper Range Limit and Span = Calibrated Span

Accuracy (a) - Differential Pressure (b)

Span Codes	Accuracy in % of Span	
	Spans ≥10% URL	Spans <10% URL
B and C	±0.05	$\pm(0.005)\left(\frac{URL}{Span}\right)$
L and A	±0.10	$\pm(0.010)\left(\frac{URL}{Span}\right)$

- (a) Accuracy stated includes the effects of linearity, hysteresis, and repeatability.
- (b) Also add ±0.025% to the accuracy to determine the total analog output accuracy if the DP measurement is assigned to the 4 to 20 mA output signal.

Accuracy (a) - Absolute Pressure (b) (c)

Span Codes	Accuracy in % of Span	
	Spans ≥10% URL	Spans <10% URL
D, E, H, and F	±0.05	$\pm(0.005)\left(\frac{URL}{Span}\right)$
Code	Spans ≥5% URL	Spans <5% URL
G	±0.05	$\pm(0.0025)\left(\frac{URL}{Span}\right)$

- (a) Accuracy stated includes the effects of linearity, hysteresis, and repeatability.
- (b) Also add ±0.025% to the accuracy to determine the total analog output accuracy if the AP measurement is assigned to the 4 to 20 mA output signal.
- (c) For gauge pressure accuracy, add anticipated variation from user-entered barometric pressure.

Accuracy - Process Temperature

±0.28°C (0.5°F) within ±140°C (250°F) of the normal operating point.

Stability

Long-term drift less than ±0.05% of URL per year over a 5-year period.

Calibration Frequency

The calibration frequency is five years. The five years is derived using the values of allowable error (% span), TPE (% span), performance margin (% span), and stability (% span/month); where:

$$\text{Calibration Frequency} = \frac{\text{Performance Margin}}{\text{Stability}} = \text{Months}$$

Power-up Time

Less than 5 seconds for output to reach first valid measurement.

Vibration Effect

±0.2% of URL per “g” for vibrations in the range of 5 to 500 Hz; with double amplitudes of 6.3 mm (0.25 in) in the range of 5 to 15 Hz, or accelerations of 3 “g” in the range of 15 to 500 Hz, whichever is smaller, for transmitter with aluminum housing; and with double amplitudes of 6.3 mm (0.25 in) in the range of 5 to 9 Hz, or accelerations of 1 “g” in the range of 9 to 500 Hz, whichever is smaller, for transmitter with 316 ss housing.

RFI Effect

The output error is less than 0.1% of span for radio frequencies in the range of 27 to 1000 MHz and field intensity of 30 V/m when the transmitter is properly installed with shielded conduit and grounding, and housing covers are in place. (Per IEC Std. 61000-4-3.)

Supply Voltage Effect

Output changes less than 0.005% of span for each 1 V change within the specified supply voltage requirements. See Figure 17.

Static Pressure Effect on Differential Pressure

The zero and span shift for a 0.7 MPa, 100 psi, change in static pressure is:

Zero Shift

Allowable Span Limit Code Combinations		Zero Shift for a 0.7 MPa (100 psi) Change:
DP	AP	in % of URL
L	G	±0.150
A	G	±0.050
B	D	±0.007
B	E	±0.010
B	H	±0.010
B	F	±0.010
C	D	±0.002
C	E	±0.004
C	H	±0.004
C	F	±0.004

Span Shift

±0.01% of Reading

Position Effect

Transmitter may be mounted in any position. Any zero effect caused by mounting position can be eliminated by rezeroing. There is no span effect.

Ambient Temperature Effect

Total effect for both absolute and differential pressure for a 28°C (50°F) change within Normal Operating Condition Limits is ±(0.03% URL + 0.06% Span); except the effect on differential pressure for DP Span Codes A and L is ±(0.18% URL + 0.025% Span). Also for AP Span Code H, the effect is ±(0.02% URL + 0.06% Span); and for AP Span Code F, the effect is ±(0.15% URL + 0.06% Span).

Switching and Indirect Lightning Transients

The transmitter can withstand a transient surge up to 2000 V common mode or 1000 V normal mode without permanent damage. Output shift is <1.0%. (Per ANSI/IEEE C62.41-1980 and IEC Std. 61000-4-5.)

Electromagnetic Compatibility

Refer to Functional Specifications section.

PHYSICAL SPECIFICATIONS

Process Cover and Connector Material (Process Wetted)

316 ss or nickel alloy (equivalent to Hastelloy® C), as specified.

Process Cover and Process Connection Gaskets

Glass filled ptfе (Chemloy)

Process Cover Bolts and Nuts

ASTM A193, Grade B7 high strength alloy steel for bolts, and ASTM A194 Grade 2H high strength alloy steel for nuts are standard. Options include NACE Class B7M bolting, 17-4 ss bolting, and 316 ss bolting. For the NACE B7M bolting option, refer to PSS 2A-1Z9 E.

Sensor Material (Process Wetted)

316L ss or nickel alloy (equivalent to Hastelloy® C), as specified

Sensor Fill Fluids

Silicone Oil or Fluorinert (FC-43)

Environmental Protection

Transmitter is dusttight and weather proof per IEC IP66 and provides the environmental and corrosion resistant protection of NEMA Type 4X.

Electronics Module

Printed wiring assemblies are conformally coated for moisture and dust protection.

Electronics Housing and Housing Covers

Housing has two compartments to separate the electronics from the field connections. The housing and covers are made from low copper, die-cast aluminum alloy with an epoxy finish, or from 316 ss. Buna-N O-ring seals are used to seal the threaded housing covers, housing neck, and terminal block.

Electrical Connections

Field and RTD sensor wires enter through 1/2 NPT, PG 13.5, or M20 threaded entrances, as specified, on either side of the electronics housing. Wires terminate under screw terminals and washers on terminal block in the field terminal compartment. Refer to Figure 22.

Mounting Position

The transmitter may be mounted in any orientation.

Approximate Mass (with Process Connectors)

- ▶ 4.2 kg (9.2 lb) with Traditional Structure
- ▶ Add 0.1 kg (0.2 lb) with Low Profile Structure LP1
- ▶ Add 0.8 kg (1.8 lb) with Low Profile Structure LP2
- ▶ Add 1.1 kg (2.4 lb) with 316 ss Housing
- ▶ Add 0.2 kg (0.4 lb) with LCD Indicator Option

Dimensions

See “Dimensions – Nominal” section and Dimensional Print DP 020-432

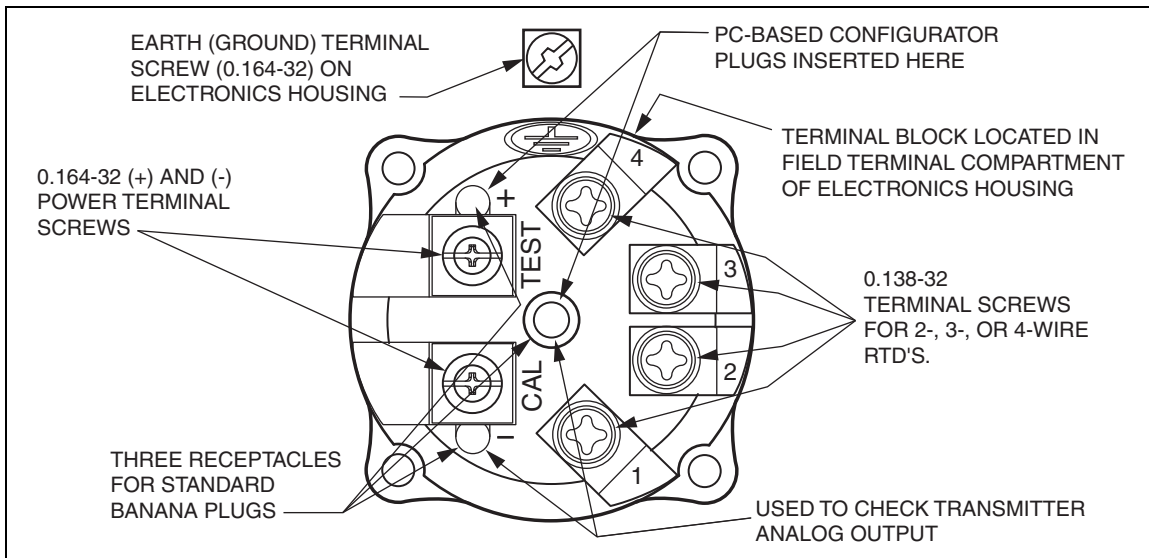

Figure 22. Field Terminal Connections

ELECTRICAL SAFETY SPECIFICATIONS

These transmitters have been designed to meet the electrical safety descriptions listed in the table that follows. For more detailed information, or status of testing laboratory approvals/certifications, contact Invensys.

Electronic Version -T (HART)

Testing Laboratory, Types of Protection, and Area Classification	Application Conditions	Electrical Safety Design Code
ATEX flameproof; II 2 GD, EEx d IIC, Zone 1.	Temperature Class T6, T85°C, Ta = -40°C to +80°C.	D
ATEX intrinsically safe; II 1 GD, EEx ia IIC, Zone 0, or II 1/2 GD, EEx ib IIC, Zone 0 and 1.	Temperature Class T4 at 80°C, T5 at 40°C, and T6 at -40°C maximum ambient.	E
ATEX protection n; II 3 GD, EEx nL IIC, Zone 2.	Temperature Class T4 at 80°C, T5 at 70°C, and T6 at -40°C maximum ambient.	N
ATEX multiple certifications, ia and ib, d, and n. Refer to ATEX Codes D, E, and N for details.	Applies to Codes D, E, and N.	M (a)
CSA intrinsically safe for Class I, Division 1, Groups A, B, C, and D, Class II, Division 1, Groups E, F, and G; Class III, Division 1. Also, zone certified intrinsically safe Ex ia IIC, and energy limited Ex nA II.	Temperature Class T4A at 40°C and T3C at 85°C maximum ambient. Temperature Class T4 at 40°C and T3 at 85°C maximum ambient.	C
CSA explosionproof for Class I, Division 1, Groups B, C, and D, and dust-ignitionproof for Class II, Division 1, Groups E, F, and G; and Class III, Division 1.	Maximum Ambient Temperature 85°C.	C
CSA Class I, Division 2, Groups A, B, C, and D; Class II, Division 2, Groups F and G; and Class III, Division 2.	Temperature Class T4A at 40°C and T3C at 85°C maximum ambient.	C
CSA field device zone certified flameproof Ex d IIC. Also, all certifications of Code C above.	Maximum Ambient Temperature 85°C.	B
FM intrinsically safe for Class I, Division 1, Groups A, B, C, and D, Class II, Division 1, Groups E, F, and G; Class III, Division 1. Also, zone approved intrinsically safe AEx ia IIC.	Temperature Class T4A at 85°C maximum ambient. Temperature Class T4 at 85°C maximum ambient.	F
FM explosionproof for Class I, Division 1, Groups B, C, and D; and dust-ignitionproof for Class II, Division 1, Groups E, F, and G; and Class III, Division 1.	Temperature Class T6 at 80°C and T5 at 85°C maximum ambient.	F
FM nonincendive Class I, Division 2, Groups A, B, C, and D; Class II, Division 2, Groups F and G, and Class III, Division 2.	Temperature Class T4A at 85°C maximum ambient.	F
FM field device zone approved flameproof AEx d IIC. Also, all certifications of Code F above.	Temperature Class T6 at 80°C and T5 at 85°C maximum ambient.	G
IECEx flameproof; Ex d IIC.	T6, Ta = 80°C; T5, Ta = 85°C; Ambient Temperature -20 to +85°C.	V

(a) When selecting ATEX Electrical Safety Design Code M, the user must permanently mark (check off in rectangle block on data plate) one type of protection only ia and ib, d, or n. This mark cannot be changed once it is applied.

MODEL CODE

MODEL CODE

Description	Model																														
I/A Series Multivariable Transmitter	IMV25																														
<p>Electronics Versions and Output Signal</p> <p>Intelligent; Digital HART and 4 to 20 mA dc (Version -T)</p>	-T																														
<p>Structure Code - Process Covers, Sensor Material, and Sensor Fill Fluid</p>																															
<p>With Traditional Structure</p>																															
<table border="0"> <thead> <tr> <th>Covers</th> <th>Sensor</th> <th>Fill Fluid</th> <th></th> </tr> </thead> <tbody> <tr> <td>316 ss</td> <td>316L ss</td> <td>Silicone</td> <td>22</td> </tr> <tr> <td>316 ss</td> <td>316L ss</td> <td>Fluorinert</td> <td>23</td> </tr> <tr> <td>316 ss</td> <td>Nickel alloy (a)</td> <td>Silicone</td> <td>26</td> </tr> <tr> <td>316 ss</td> <td>Nickel alloy (a)</td> <td>Fluorinert</td> <td>27</td> </tr> <tr> <td>Nickel alloy (a)</td> <td>Nickel alloy (a)</td> <td>Silicone</td> <td>46</td> </tr> <tr> <td>Nickel alloy (a)</td> <td>Nickel alloy (a)</td> <td>Fluorinert</td> <td>47</td> </tr> </tbody> </table>	Covers	Sensor	Fill Fluid		316 ss	316L ss	Silicone	22	316 ss	316L ss	Fluorinert	23	316 ss	Nickel alloy (a)	Silicone	26	316 ss	Nickel alloy (a)	Fluorinert	27	Nickel alloy (a)	Nickel alloy (a)	Silicone	46	Nickel alloy (a)	Nickel alloy (a)	Fluorinert	47			
Covers	Sensor	Fill Fluid																													
316 ss	316L ss	Silicone	22																												
316 ss	316L ss	Fluorinert	23																												
316 ss	Nickel alloy (a)	Silicone	26																												
316 ss	Nickel alloy (a)	Fluorinert	27																												
Nickel alloy (a)	Nickel alloy (a)	Silicone	46																												
Nickel alloy (a)	Nickel alloy (a)	Fluorinert	47																												
<p>With Low Profile Structure LP1</p>																															
<table border="0"> <thead> <tr> <th>Covers</th> <th>Sensor</th> <th>Fill Fluid</th> <th></th> </tr> </thead> <tbody> <tr> <td>316 ss</td> <td>316L ss</td> <td>Silicone</td> <td>LL</td> </tr> <tr> <td>316 ss</td> <td>316L ss</td> <td>Fluorinert</td> <td>LM</td> </tr> <tr> <td>316 ss</td> <td>Nickel alloy (a)</td> <td>Silicone</td> <td>LC</td> </tr> <tr> <td>316 ss</td> <td>Nickel alloy (a)</td> <td>Fluorinert</td> <td>LD</td> </tr> </tbody> </table>	Covers	Sensor	Fill Fluid		316 ss	316L ss	Silicone	LL	316 ss	316L ss	Fluorinert	LM	316 ss	Nickel alloy (a)	Silicone	LC	316 ss	Nickel alloy (a)	Fluorinert	LD											
Covers	Sensor	Fill Fluid																													
316 ss	316L ss	Silicone	LL																												
316 ss	316L ss	Fluorinert	LM																												
316 ss	Nickel alloy (a)	Silicone	LC																												
316 ss	Nickel alloy (a)	Fluorinert	LD																												
<p>With Low Profile Structure LP2</p>																															
<table border="0"> <thead> <tr> <th>Covers</th> <th>Sensor</th> <th>Fill Fluid</th> <th></th> </tr> </thead> <tbody> <tr> <td>316 ss</td> <td>316L ss</td> <td>Silicone</td> <td>52</td> </tr> <tr> <td>316 ss</td> <td>316L ss</td> <td>Fluorinert</td> <td>53</td> </tr> <tr> <td>316 ss</td> <td>Nickel alloy (a)</td> <td>Silicone</td> <td>56</td> </tr> <tr> <td>316 ss</td> <td>Nickel alloy (a)</td> <td>Fluorinert</td> <td>57</td> </tr> </tbody> </table>	Covers	Sensor	Fill Fluid		316 ss	316L ss	Silicone	52	316 ss	316L ss	Fluorinert	53	316 ss	Nickel alloy (a)	Silicone	56	316 ss	Nickel alloy (a)	Fluorinert	57											
Covers	Sensor	Fill Fluid																													
316 ss	316L ss	Silicone	52																												
316 ss	316L ss	Fluorinert	53																												
316 ss	Nickel alloy (a)	Silicone	56																												
316 ss	Nickel alloy (a)	Fluorinert	57																												
<p>Span Limits - Differential Pressure (DP) Measurement</p>																															
<table border="0"> <thead> <tr> <th>kPa</th> <th>inH₂O</th> <th>mbar</th> <th>Available with AP Span Limit Codes: (b)</th> <th></th> </tr> </thead> <tbody> <tr> <td>0.12 and 2.5</td> <td>0.5 and 10</td> <td>1.2 and 25</td> <td>G only</td> <td>L</td> </tr> <tr> <td>0.75 and 7.5</td> <td>3 and 30</td> <td>7.5 and 75</td> <td>G only</td> <td>A</td> </tr> <tr> <td>0.5 and 50</td> <td>2 and 200</td> <td>5 and 500</td> <td>D, E, H and F only</td> <td>B</td> </tr> <tr> <td>2.5 and 210</td> <td>10 and 840</td> <td>25 and 2100</td> <td>D, E, H and F only</td> <td>C</td> </tr> </tbody> </table>	kPa	inH ₂ O	mbar	Available with AP Span Limit Codes: (b)		0.12 and 2.5	0.5 and 10	1.2 and 25	G only	L	0.75 and 7.5	3 and 30	7.5 and 75	G only	A	0.5 and 50	2 and 200	5 and 500	D, E, H and F only	B	2.5 and 210	10 and 840	25 and 2100	D, E, H and F only	C						
kPa	inH ₂ O	mbar	Available with AP Span Limit Codes: (b)																												
0.12 and 2.5	0.5 and 10	1.2 and 25	G only	L																											
0.75 and 7.5	3 and 30	7.5 and 75	G only	A																											
0.5 and 50	2 and 200	5 and 500	D, E, H and F only	B																											
2.5 and 210	10 and 840	25 and 2100	D, E, H and F only	C																											
<p>Span Limits - Absolute Pressure (AP) Measurement (Absolute Measured: Gauge Calculated)</p>																															
<table border="0"> <thead> <tr> <th>MPaa</th> <th>psia</th> <th>bara or kg/cm² abs</th> <th>Available with DP Span Limit Codes: (b)</th> <th></th> </tr> </thead> <tbody> <tr> <td>0.02 and 2.1</td> <td>3 and 300</td> <td>0.21 and 21</td> <td>B and C only</td> <td>D</td> </tr> <tr> <td>0.07 and 3.5</td> <td>10 and 500</td> <td>0.7 and 35</td> <td>L and A only</td> <td>G</td> </tr> <tr> <td>0.21 and 10</td> <td>30 and 1500</td> <td>2.1 and 100</td> <td>B and C only</td> <td>E</td> </tr> <tr> <td>0.42 and 20</td> <td>60 and 3000</td> <td>4.2 and 200</td> <td>B and C only</td> <td>H</td> </tr> <tr> <td>3.4 and 36.5</td> <td>500 and 5300</td> <td>34 and 365</td> <td>B and C only</td> <td>F</td> </tr> </tbody> </table>	MPaa	psia	bara or kg/cm ² abs	Available with DP Span Limit Codes: (b)		0.02 and 2.1	3 and 300	0.21 and 21	B and C only	D	0.07 and 3.5	10 and 500	0.7 and 35	L and A only	G	0.21 and 10	30 and 1500	2.1 and 100	B and C only	E	0.42 and 20	60 and 3000	4.2 and 200	B and C only	H	3.4 and 36.5	500 and 5300	34 and 365	B and C only	F	
MPaa	psia	bara or kg/cm ² abs	Available with DP Span Limit Codes: (b)																												
0.02 and 2.1	3 and 300	0.21 and 21	B and C only	D																											
0.07 and 3.5	10 and 500	0.7 and 35	L and A only	G																											
0.21 and 10	30 and 1500	2.1 and 100	B and C only	E																											
0.42 and 20	60 and 3000	4.2 and 200	B and C only	H																											
3.4 and 36.5	500 and 5300	34 and 365	B and C only	F																											
<p>Other Measurements</p>																															
<p>Temperature - Terminal Block supports Connection of External, 100 ohm Platinum RTD (DIN/IEC)</p>	1																														

MODEL CODE (CONTINUED)

Description	Model
Process Connector Type (Material Same as Process Cover Material)	
None, Covers tapped for 1/4 NPT	0
1/4 NPT (Not Available with Structure Codes 46 and 47 - Nickel alloy (a) Process Covers)	1
1/2 NPT	2
Rc 1/4 (Not Available with Structure Codes 46 and 47 - Nickel alloy (a) Process Covers)	3
Rc 1/2	4
1/2 Schedule 80 Welding Neck (Not Available with Structure Codes 46 and 47 - Nickel alloy (a) Process Covers)	6
Conduit Connection and Housing Material	
1/2 NPT Connection, Aluminum Housing	1
PG 13.5 Connection, Aluminum Housing (Available with Electrical Safety Codes E, D, M, and N only)	2
1/2 NPT Connection, 316 ss Housing	3
PG 13.5 Connection, 316 ss Housing (Available with Electrical Safety Codes E, D, M, and N only)	4
M20 Connection, Aluminum Housing (Available with Electrical Safety Codes E, D, M, and N only)	5
M20 Connection, 316 ss Housing (Available with Electrical Codes E, D, M, and N only)	6
Electrical Safety (Also see Electrical Safety Specifications section)	
ATEX II 1 GD, EEx ia IIC, Zone 0; or II 1/2 GD, EEx ib IIC, Zone 0/Zone 1	E
ATEX II 2 GD, EEx d IIC, Zone 1 (c)	D
ATEX II 3 GD, EEx nL IIC, Zone 2	N
ATEX Multiple Certifications (includes ATEX Codes E, D, and N) (c) (See Electrical Safety Specifications section for <u>user marking</u>)	M
CSA Certifications:	
Division 1 explosionproof and dust-ignitionproof	C
Division 1 intrinsically safe, also zone certified Ex ia IIC, and Ex nL II	
Division 2, Classes I, II, and III	
CSA Certifications: (c)	
Zone certified flameproof Ex d IIC. Also all certifications of Code C above	B
FM Approvals:	
Division 1 explosionproof and dust-ignitionproof	F
Division 1 intrinsically safe, also zone approved AEx ia IIC	
Division 2, Classes I, II, and III; nonincendive	
FM Approvals: (c)	
Zone approved flameproof AEx d IIC. Also all certifications of Code F above	G
IECEx flameproof, Ex d IIC	
	V
Optional Selections (See PSS 2A-1Z9 E for Options/Accessories not in Model Code)	
Refer to Optional Selection descriptions that follow.	
Mounting Bracket Set (d)	
Standard Style Painted Steel Bracket with Plated Steel Bolts	-M1
Standard Style Stainless Steel Bracket with Stainless Steel Bolts	-M2
Universal Style Stainless Steel Bracket with Stainless Steel Bolts	-M3
Digital Indicator with Pushbuttons	
Digital Indicator, Pushbuttons, and Window Cover	-L1

MODEL CODE

MODEL CODE (CONTINUED)

Description	Model
DIN 19213 Construction used with Process Connector Code "0" and 316 ss Process Covers Only	
Process Cover Type	Cover Screw Material
Connector Screw Size	Connector Screw Material
Single Ended (e)	Steel
M10 (by User)	—
Double Ended (f) (g)	Steel
M10	Steel
(Blind Kidney Flange on back)	
Single Ended (e)	Steel
7/16 (by User)	—
Double Ended (f) (g)	Steel
7/16	Steel
(Blind Kidney Flange on back)	
Single Ended (e)	316 ss
7/16 (by User)	—
Double Ended (f) (g)	316 ss
7/16	316 ss
(Blind Kidney Flange on back)	
Single Ended (e)	17-4 ss
7/16 (by User)	—
Double Ended (f) (g)	17-4 ss
7/16	17-4 ss
(Blind Kidney Flange on back)	
Cleaning and Preparation	
Unit Degreased - for Silicone Filled Sensors Only (Not for Oxygen/Chlorine/Other Fluids that may react with Silicone)	-X1
Cleaned and Prepared for Oxygen Service - for Fluorinert Filled Sensors Only	-X2
Cleaned and Prepared for Chlorine Service - for Fluorinert Filled Sensors Only (includes 17-4 ss bolting; therefore do not also specify Option -B2)	-X3
Bolting for Process Covers/Connectors - Not Available with DIN 19213 Construction	
316 ss Bolts and Nuts (h)	-B1
17-4 ss Bolts and Nuts (h)	-B2
B7M Bolts and Nuts (h) (i)	-B3
Conduit Connectors	
Hawke-Type 1/2 NPT Cable Gland for use with Conduit Connection Codes 1 and 3 Available with Electrical Safety Codes E, D, M, and N only	-A1
M20 Conduit Thread Adapter for use with Conduit Connection Codes 1 and 3 Available with Electrical Safety Codes E, D, M, and N only	-A3
Electronics Housing Features	
Custody Transfer Lock and Seal	-Z2
Tubing Connectors	
316 ss, Connecting 6 mm Tubing to 1/4 NPT Process Connector (j)	-E3
316 ss, Connecting 12 mm Tubing to 1/2 NPT Process Connector (k)	-E4
Custom Factory Configuration	
Full Factory Configuration (Requires Configuration Form to be Filled Out)	-C2
Vent Screw in Process Cover	
Supply Vent Screw in Side of Each Process Cover (Available only on Traditional Process Cover Structure Codes 22 to 47)	-V
Omit Vent Screw in Side of Each Process Cover (Available only on Type LP1 Low Profile Process Cover Structures Codes LL, LM, LC, and LD)	-V1

MODEL CODE (CONTINUED)

Description	Model
Adapter Plate, Bolts, and Gaskets for Direct Mount to Competitive Manifolds (I)	
See inside pages for manifold compatibility.	
Adapter Set for MC Coplanar Manifolds, B7 Bolts (not with options -B1, -B2, or -B3)	-P1
Adapter Set for MC Coplanar Manifolds, 316 ss Bolts (requires -B1 option)	-P2
Adapter Set for MC Coplanar Manifolds, 17-4 ss Bolts (requires -B2 option)	-P3
Adapter Set for MC Coplanar Manifolds, B7M Bolts (requires -B3 option)	-P4
Adapter Set for MT3 Coplanar Manifolds, Traditional Flange, B7 Bolts (not with options -B1, -B2, or -B3)	-P5
Adapter Set for MT3 Coplanar Manifolds, Traditional Flange, 316 ss Bolts (requires -B1 option)	-P6
Adapter Set for MT3 Coplanar Manifolds, Traditional Flange, 17-4 ss Bolts (requires -B2 option)	-P7
Adapter Set for MT3 Coplanar Manifolds, Traditional Flange, B7M Bolts (requires -B3 option)	-P8
Instruction Books (Common MI, Brochure, and Full Documentation Set on CD-ROM is Standard)	
Without Instruction Book and CD; only "Getting Started" brochure is supplied	-K1
Miscellaneous Optional Selections	
Low Temperature Operative Limits of Electronics Housing Extended down to -50°C (-58°F) (m) (n)	-J
Supplemental Customer Tag (Stainless Steel Tag wired onto Transmitter)	-T
Example: IMV25-T22BD121F-M1L1	

- (a) Equivalent to Hastelloy® C.
- (b) See Span and Range Limits tables in Functional Specifications section for allowable DP and AP Span Limit Code combinations.
- (c) A cover lock is provided as standard construction with Electrical Safety Codes D, B, G, and M.
- (d) When selected with Structure Codes LL, LM, LC, or LD, the Process Connector Code must be 0.
- (e) Not available with Low Profile Structure Codes 52-57.
- (f) Not available with Low Profile Structure Codes 52 to 57, and LL, LM, LC, or LD.
- (g) Temperature limits are 0 and 60°C (32 and 140°F) with Options -D2, -D4, -D6, and -D8. Also not available with Mounting Bracket Sets -M1, -M2, and -M3.
- (h) Not available with DIN 19213 Construction Options -D1 to -D8. Select Option Codes -D5 to -D8 to get stainless bolting on DIN 19213 Transmitters.
- (i) Selection of Option -B3 normally requires selection of Auxiliary Specification (AS) MR-01 (NACE Standard MR 01-75).
- (j) Only available with Structure Codes 22 and 23; and only with Process Connector Codes 0 and 1.
- (k) Only available with Structure Codes 22 and 23; and only with Process Connector Code 2.
- (l) Adapter plate options -P1 to -P8 are not available with:
 - Process Connector Codes 1-7.
 - DIN Construction Options -D1, -D2, -D4, -D5, -D6, -D7, and -D8.
- (m) Option -J not available with:
 - Structures with Fluorinert Fill (Codes 23, 27, 47, LM, LD, 53, and 57)
 - DIN Construction Options -D2, -D4, -D6, and -D8.
- (n) -50°C indicates sensor and electronics ambient temperature capabilities. Performance is not assured below -29°C. Sensor damage may occur if process is frozen.

SUGGESTED RFQ SPECIFICATIONS

The manufacturer shall provide field-mounted, multivariable transmitter(s) featuring HART Communication Protocol. They shall provide remote digital communications capability for measuring absolute pressure, differential pressure, and temperature, and transmitting a digital or 4 to 20 mA dc output signal for use in a standard two-wire dc supply voltage system. The specifications for this Multivariable transmitter are as follows:

Communication Protocol:	HART: Digital and/or 4 to 20 mA dc output signal
Remote Communications:	Must not interfere with output
Accuracy:	Digital Output: $\pm 0.05\%$ of calibrated span 4 to 20 mA Output: $\pm 0.075\%$ of calibrated span
Damping:	Settable for a range of none to 32 seconds
RFI Protection:	0.1% error between 27 and 1000 MHz at 30 V/m field intensity
Span Limits:	Absolute Pressure Measurement 3 and 300 psi, 10 and 500 psi, 30 and 1500 psi, 60 and 3000 psi, and 500 and 5300 psi, or SI and Metric Equivalents Differential Pressure Measurement 0.5 and 10 inH ₂ O, 3 and 30 inH ₂ O, 2 and 200 inH ₂ O, and 10 and 840 inH ₂ O, or SI and Metric Equivalents
Process Temperature:	Transmitter includes terminals to receive either a 2-, 3-, or 4-wire, 100 ohm, platinum DIN/IEC RTD to measure process temperature. Range Limits are -200 and +850°C (-328 and 1562°F).
Mounting:	On process piping, optional mounting bracket, or to a manifold.
Input Connection:	With process connectors to accept 1/4 NPT, 1/2 NPT, Rc 1/4 or Rc 1/2, 1/2 Schedule 80 welding neck
Electronics Housing:	Aluminum housing with epoxy finish, or 316 ss housing; with 1/2 NPT, PG 13.5, or M20 conduit connections.
Modular Electronics:	Easily replaceable modular electronics in a NEMA 4X (IEC IP66) housing sealed with O-rings for protection against moisture or other contaminants. Optional integral LCD Indicator with on-board configuration pushbuttons.
Process Covers:	Traditional Structure: 316 ss or nickel alloy (equivalent to Hastelloy® C). Low Profile Structures (LP1 and LP2): 316 ss.
Sensor Materials Available:	316L ss or nickel alloy (equivalent to Hastelloy® C) for both traditional and low profile structures.
Approvals and Certifications:	Must be suitable for Division 1 and Zone 0/Zone 1 hazardous area locations, and conform to all applicable European Union Directives. Versions available to meet agency flameproof and zone requirements.
Approximate Mass: (with Process Connectors)	4.2 kg (9.2 lb), with traditional Structure; Add 0.1 kg (0.2 lb) – with Low Profile Structure LP1; Add 0.8 kg (1.8 lb) – with Low Profile Structure LP2; Add 1.1 kg (2.4 lb) – with 316 ss housing; Add 0.2 kg (0.4 lb) – with optional LCD indicator.
Model Code:	I/A Series Intelligent IMV25 Multivariable Transmitter with HART Communication Protocol, or equivalent

DIMENSIONS - NOMINAL

TRANSMITTER WITH TRADITIONAL STRUCTURE

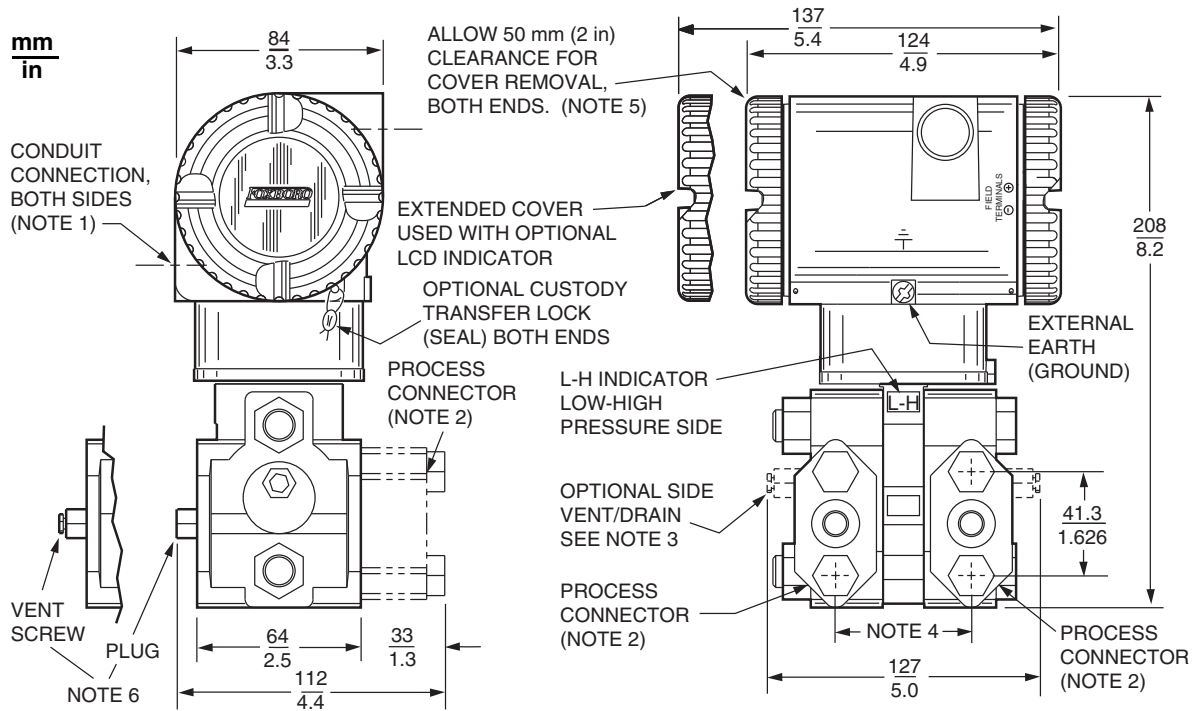

NOTES:

1. CONDUIT CONNECTION 1/2 NPT, PG 13.5, OR M20, BOTH SIDES: PLUG UNUSED CONNECTION WITH METAL PLUG (SUPPLIED).
2. PROCESS CONNECTORS MAY BE REMOVED AND TRANSMITTER MOUNTED DIRECTLY ON A MANIFOLD, OR CONNECTIONS MADE DIRECTLY TO PROCESS COVER USING 1/4 NPT INTERNAL THREAD IN PROCESS COVER.
3. PROCESS COVER CAN BE INVERTED MAKING OPTIONAL SIDE VENTS OR SIDE DRAINS
4. PROCESS CONNECTORS CAN BE INVERTED TO GIVE EITHER 51, 54, OR 57 mm (2.0, 2.125, OR 2.25 in) CENTER-TO-CENTER DISTANCE BETWEEN HIGH AND LOW PRESSURE CONNECTIONS.
5. TOPWORKS CAN BE ROTATED TO ANY POSITION WITHIN ONE TURN COUNTERCLOCKWISE OF THE FULLY TIGHTENED POSITION.
6. PROCESS COVER END PLUGS ARE SUBSTITUTED FOR VENT SCREWS WHEN OPTIONAL SIDE VENTS (NOTE 3) ARE SPECIFIED.

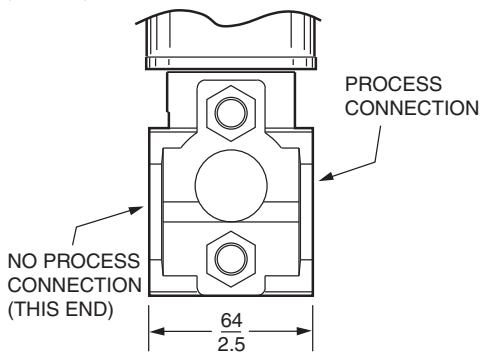

OPTIONAL DIN CONSTRUCTION
SINGLE ENDED PROCESS COVER
OPTIONS -D1, -D3, -D5, AND -D7

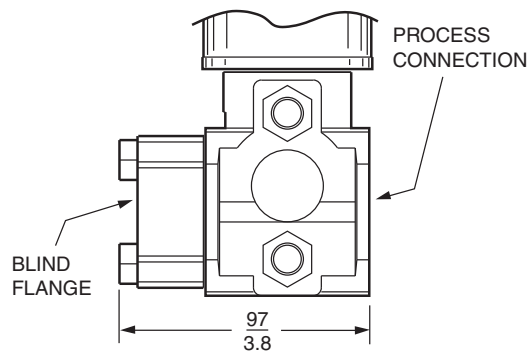

OPTIONAL DIN CONSTRUCTION
DOUBLE ENDED PROCESS COVER
OPTIONS -D2, -D4, -D6, AND -D8

mm
in

TRANSMITTER WITH LOW PROFILE STRUCTURE LP1

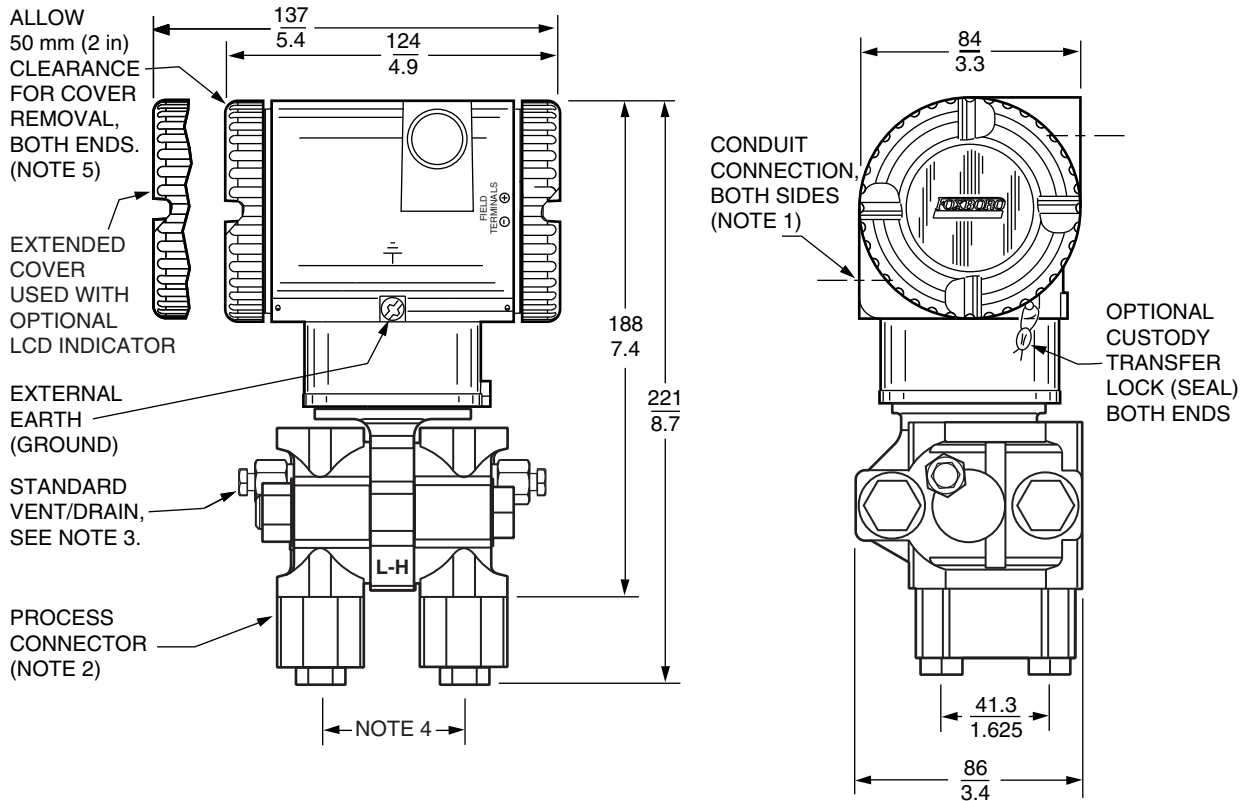

NOTES:

1. CONDUIT CONNECTION 1/2 NPT, PG 13.5, OR M 20, BOTH SIDES: PLUG UNUSED CONNECTION WITH METAL PLUG (SUPPLIED).
2. PROCESS CONNECTORS MAY BE REMOVED AND TRANSMITTER MOUNTED DIRECTLY ON A MANIFOLD, OR CONNECTIONS MADE DIRECTLY TO PROCESS COVER USING 1/4 NPT INTERNAL THREAD IN PROCESS COVER.
3. THE TRANSMITTER'S LOW PROFILE STRUCTURE LP1 IS SHOWN IN THE VERTICALLY UPRIGHT POSITION. NOTE THE LOCATION OF THE STANDARD VENT/DRAIN SCREW. IN THIS CONFIGURATION THE TRANSMITTER CAN BE VENTED OR IS SELF-DRAINING. ALSO RECOMMENDED IS A HORIZONTAL INSTALLATION WHERE THE INSTALLED ORIENTATION CAN BE SET TO ALLOW FOR VENTING OR DRAINING.
4. PROCESS CONNECTORS CAN BE INVERTED TO GIVE EITHER 51, 54, OR 57 mm (2.0, 2.125, OR 2.25 in) CENTER-TO-CENTER DISTANCE BETWEEN HIGH AND LOW PRESSURE CONNECTIONS.
5. TOPWORKS CAN BE ROTATED TO ANY POSITION WITHIN ONE TURN COUNTERCLOCKWISE OF THE FULLY TIGHTENED POSITION.

mm
in

TRANSMITTER WITH LOW PROFILE STRUCTURE LP2

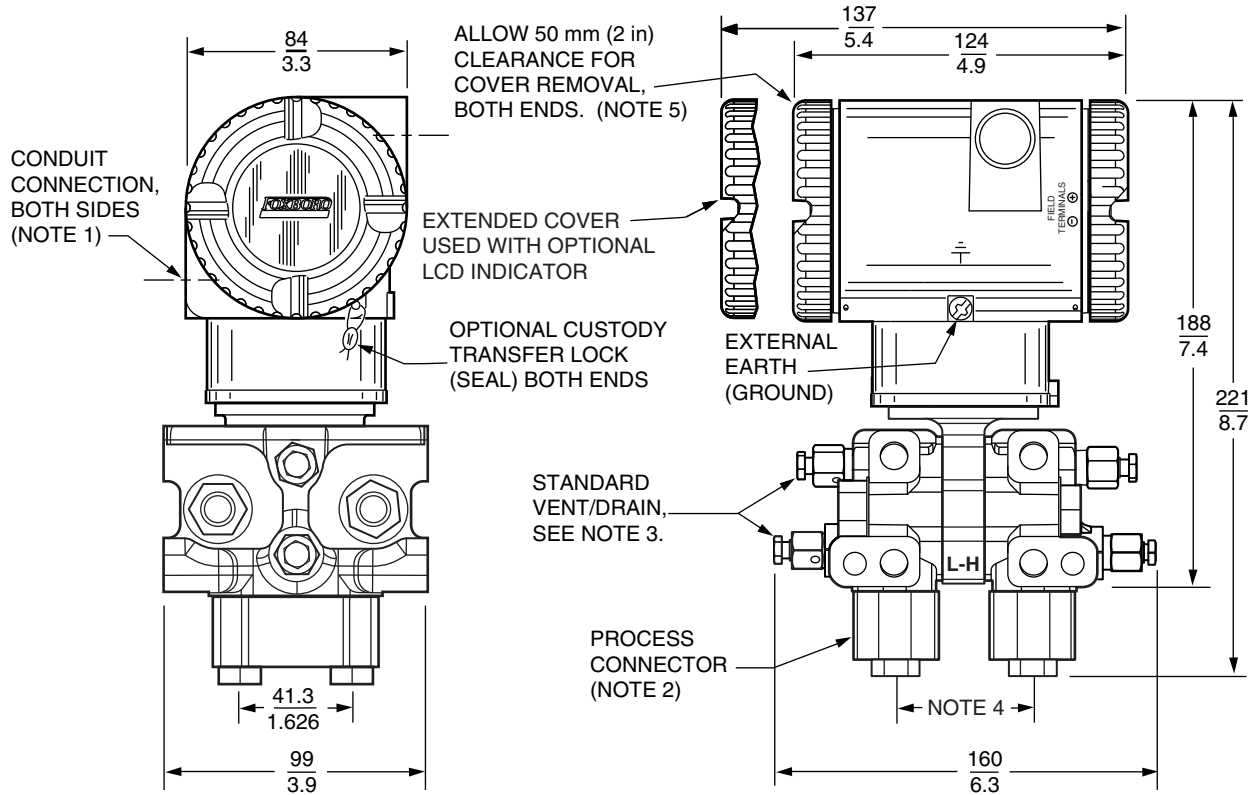

NOTES:

1. CONDUIT CONNECTION 1/2 NPT, PG 13.5, OR M 20, BOTH SIDES: PLUG UNUSED CONNECTION WITH METAL PLUG (SUPPLIED).
2. PROCESS CONNECTORS MAY BE REMOVED AND TRANSMITTER MOUNTED DIRECTLY ON A MANIFOLD, OR CONNECTIONS MADE DIRECTLY TO PROCESS COVER USING 1/4 NPT INTERNAL THREAD IN PROCESS COVER.
3. THE TRANSMITTER'S LOW PROFILE STRUCTURE LP2 IS SHOWN IN THE RECOMMENDED VERTICAL UPRIGHT POSITION. NOTE THE STANDARD VENT OR DRAIN SCREWS. HORIZONTAL INSTALLATIONS ARE NOT RECOMMENDED.
4. PROCESS CONNECTORS CAN BE INVERTED TO GIVE EITHER 51, 54, OR 57 mm (2.0, 2.125, OR 2.25 in) CENTER-TO-CENTER DISTANCE BETWEEN HIGH AND LOW PRESSURE CONNECTIONS.
5. TOPWORKS CAN BE ROTATED TO ANY POSITION WITHIN ONE TURN COUNTERCLOCKWISE OF THE FULLY TIGHTENED POSITION.

$\frac{\text{mm}}{\text{in}}$

TRANSMITTER WITH STANDARD STYLE MOUNTING BRACKET KIT (Options -M1 and -M2)

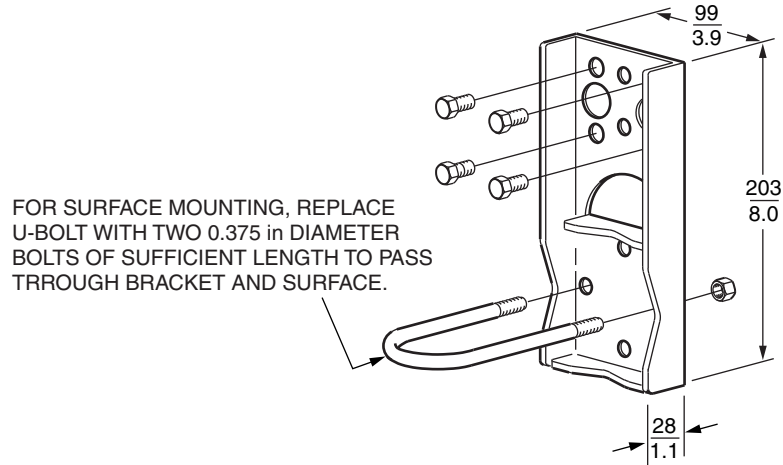

TRANSMITTER WITH TRADITIONAL STRUCTURE

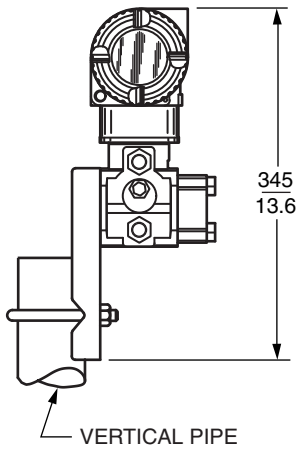

TRANSMITTER WITH LOW PROFILE STRUCTURE LP2

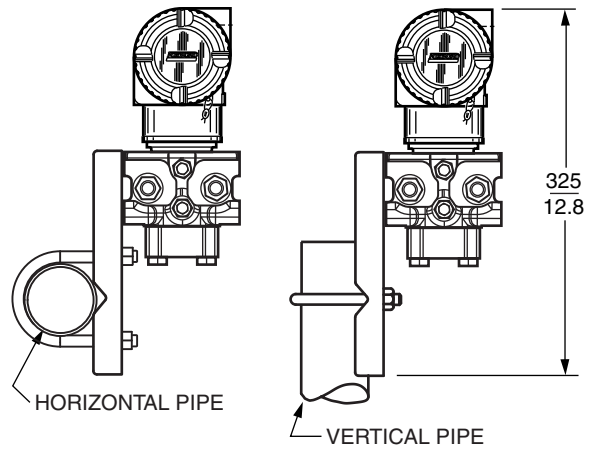

NOTE: Refer to Dimensional Print DP 020-432 for further information.

mm
in

TRANSMITTER WITH UNIVERSAL STYLE MOUNTING BRACKET KIT (Option -M3)

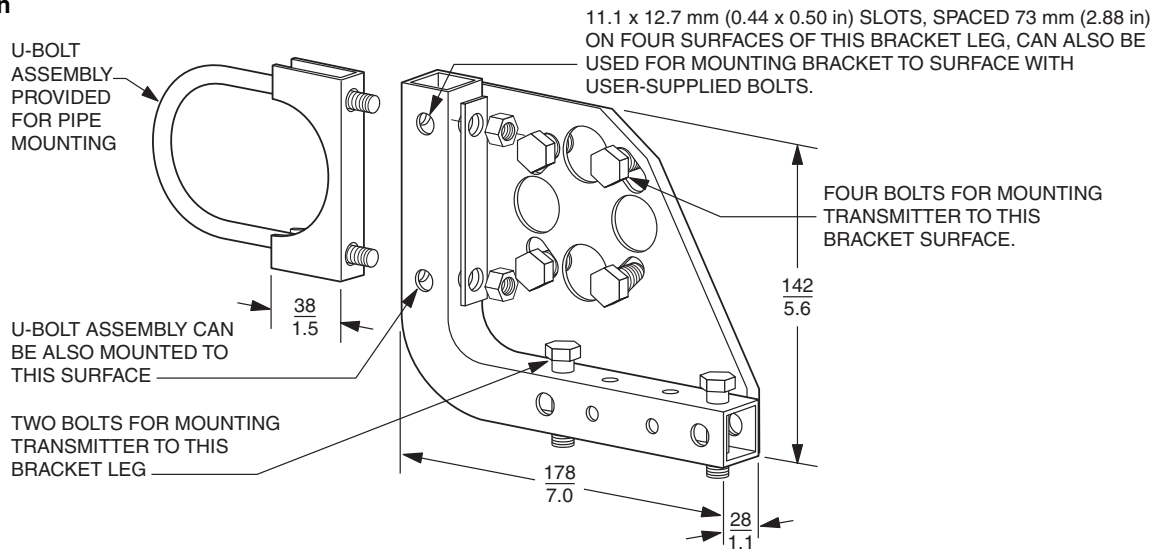

TYPICAL PIPE MOUNTING WITH LOW PROFILE STRUCTURE LP2

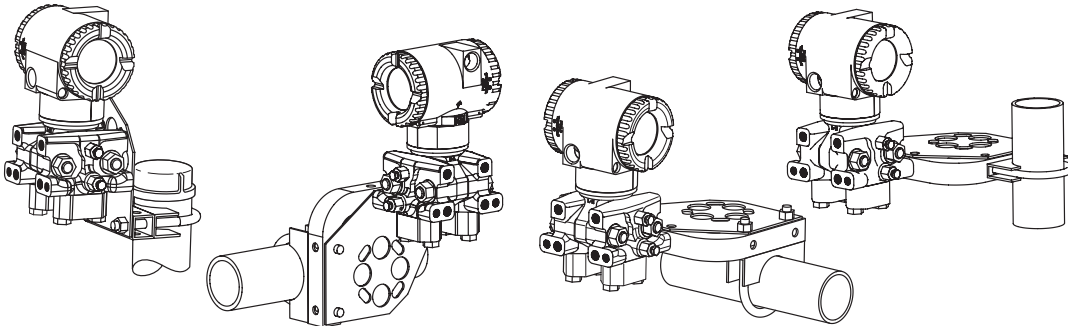

TYPICAL PIPE MOUNTING
LOW PROFILE STRUCTURE LP1

TYPICAL PIPE MOUNTING
WITH TRADITIONAL STRUCTURE

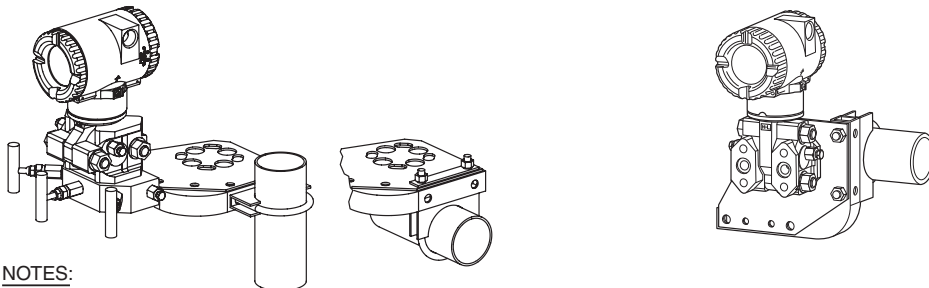

NOTES:

1. FOR SURFACE MOUNTING CONFIGURATIONS, USE THE U-BOLT MOUNTING HOLES FOR ATTACHING THE BRACKET TO A SURFACE RATHER THAN TO THE U-BOLT ASSEMBLY. SURFACE MOUNTING BOLTS FOR ATTACHING THE BRACKET TO A SURFACE ARE USER SUPPLIED.
2. REFER TO DIMENSIONAL PRINT DP 020-432 FOR FURTHER IMV25 MOUNTING CONFIGURATIONS, INCLUDING MOUNTING WITH -P MOUNTING PLATES.

NOTES



ORDERING INSTRUCTIONS

1. Model Number.
2. Calibrated Pressure Ranges for both DP and AP using allowable pressure units from the table below.
3. Configuration Data Form when Factory Configuration Option -C2 is specified.
4. Optional Features and Accessories not Included in Model Code (See PSS 2A-1Z9 E).
5. User Tag Data - Data Plate, 32 characters maximum.
For additional Tag Data, specify Optional Supplemental Tag -T.
6. User Tag Data - Software (Database): Version -T, HART; 8 characters maximum.

Table 2. Allowable Pressure Units for Calibrated Range

inH ₂ O	inHg	Pa	torr	g/cm ²	psia
ftH ₂ O	mmHg	kPa	mbar	kg/cm ²	atm
mmH ₂ O		MPa	bar		

OTHER M&I PRODUCTS

Invensys provides a broad range of measurement and instrument products, including solutions for pressure, flow, analytical, positioners, temperature, controlling and recording. For a listing of these offerings, visit the Invensys Operations Management web site at:

www.iom.invensys.com