

**Model CFT51 Digital Coriolis Mass Flow and Density Transmitter
with HART or Modbus Communication Protocol**



The Foxboro® brand Model CFT51 Digital Coriolis Mass Flow and Density Transmitter combines with a Model CFS10 or CFS20 Mass Flowtube to form an I/A Series Mass Flow and Density Meter. The CFT51 uses HART or Modbus protocol for remote communications. The CFT51 is the next generation of the CFT50, and provides the features listed below.

FEATURES

- ▶ Patented digital signal processing (DSP) techniques allow:
 - Continuous 2-phase measurement.
 - Partial empty tube conditions.
 - Start-from-empty batching.
 - On-line flowtube verification.
 - On-line pressure compensation.
- ▶ User-configurable, externally powered I/O types isolated from each other include: analog current output and alarm, frequency or scaled pulse output, contact output, contact input.
- ▶ Quadrature pulse output for custody transfer applications.
- ▶ User-selectable HART or Modbus communication via LCD Indicator pushbuttons.
- ▶ Remote communication with HART communicator or PC-based configurator.
- ▶ Local configuration via Indicator with pushbuttons.
- ▶ Available for ac or dc supply voltage applications.
- ▶ Transmitter is backward compatible to existing CFS10 and CFS20 flowtube installations.
- ▶ Tamperproof Sealing for housing and terminal block covers is provided.
- ▶ Weights and Measures Custody Transfer (NTEP) option is provided.
- ▶ Weights and Measures Industry Canada Approval option is provided.
- ▶ Enclosure can be remote-mounted to a surface, or DN80 (3 inch) or DN50 (2 inch) pipe.
- ▶ Enclosure meets NEMA 4X and IEC IP66/67 ratings.
- ▶ Transmitter certified for use in hazardous area locations. Agency plate includes CE mark.

INTRODUCTION

This I/A Series® Mass Flow and Density Meter, comprising a CFT51 Mass Flow and Density Transmitter and a CFS10 or CFS20 Mass Flowtube, measures fluid mass flow rate directly, not inferentially. The direct measurement of mass eliminates the inaccuracies of multiple process measurements associated with volumetric flow devices are eliminated.

The Model CFT51 Digital Coriolis Mass Flow and Density transmitter is an advanced generation of mass flow devices using DSP (digital signal processing) technology, which allows this transmitter to provide improved performance over other Coriolis flowmeters.

Ideally suited for tank and railcar loading and unloading, the CFT51 transmitter allows for continuous 2-phase measurement, partial empty tube conditions, and start-from-empty batching. It also allows the Foxboro® mass flowtubes to continue operation during transition from a liquid to a gas, and back again.

The CFT51 is an enhanced version of the CFT50 in that it provides all the features available with the CFT50 transmitter, and it also provides on-line flowtube verification and on-line pressure compensation capabilities. In addition, the CFT51 LCD keypad allows you to select and use either the HART® or Modbus™ digital communication interface.

The transmitter provides multiple measurements, remote communications, and selectable multiple current outputs, pulse outputs, contact outputs, and contact inputs.

In addition to the above, automated manufacturing processes, coupled with superior construction and testing all add up to an ideal product for today and tomorrow's "real world" process flow applications.

PATENTED ON-LINE FLOWTUBE VERIFICATION

Special features are provided in the CFT51 transmitter to identify adverse effects such as erosion, corrosion, and flowtube coating.

OTHER PRODUCT PATENTS

This product and its components are protected by one or more of the following US patents: 6311136, 6505519, 6507791, 6754594, 6758102, 6917887, 6950760, 6981424, 7124646, 7136761, 7146280, 7404336, 7505854, 7571062, 7784360, 8000906.

APPLICATION VERSATILITY

- ▶ Programmable alarms, contacts, and relays
- ▶ Digital circuitry that eliminates zero drift
- ▶ High accuracy over a wide range of flow rates
- ▶ Remote and local configuration
- ▶ Direct measurement of mass, density, and temperature
- ▶ Density optimization that provides unsurpassed density accuracy
- ▶ Selection of measurements, such as Volume, Volume Total, Mass Total, % Concentration, % Solids, Net Flow, °Brix, and °Baumé
- ▶ Suitable for applications including:
 - Tanker unloading
 - Centrifuge bottoms
 - Ethylene oxide
 - Sanitary batching
 - Pharmaceuticals batching
 - Food, dairy, and beverage
 - Custody transfer with quadrature pulse output
 - Net oil
 - Bunker fuels transfer
 - Wet Gas

HART COMMUNICATION PROTOCOL

The HART 4 to 20 mA output signal allows direct analog connection to common receivers while still providing full Intelligent Transmitter Digital Communications using a HART Communicator or PC-based configurator such as the PC50 Field Device Tool or Model HHT50 Configurator.

Measurements and diagnostics are available from the communicator connected to the two-wire loop carrying the 4 to 20 mA signal by using a bidirectional digital signal superimposed on the 4 to 20 mA current signal. Multidrop configurations are also supported.

Multiple measurements are transmitted digitally in a choice of engineering units (EGUs). Transmitter diagnostics are also communicated. Configuration and reranging can be accomplished remotely with the communicator or PC-based configurator, or locally with the LCD indicator with pushbuttons.

MODBUS COMMUNICATION PROTOCOL

Communication with host processors is made using the Modbus RTU (Remote Terminal Unit) mode over a 2-wire RS-485 multidrop serial connection.

The CFT51 uses the Modcom RTU mode, rather than the ASCII mode, for communication. The main advantage of the RTU mode is that its greater character density allows better data throughput than ASCII for the same baud rate. Each message must be transmitted in a continuous stream. The CFT51 functions as a Modbus slave device.

Modbus Station Addresses Supported

Station (or slave) addresses supported are in the range of 1 to 247.

Modbus Floating Point Support

Each Modbus register is a 16-bit register. Floating-point numbers in the CFT51 are each stored in two consecutive registers. Floating-point values must be retrieved by requesting the contents of both registers with the same poll command. Both registers of a floating-point value must be written in the same Modbus message. The floating-point numbers should be interpreted according to the IEEE-754 floating-point format for 32-bit numbers. Floating Point Byte order is selectable.

COMPLIANCE WITH EUROPEAN UNION DIRECTIVES

- ▶ Complies with Electromagnetic Compatibility Requirements of European EMC Directive 2004/108/EC by conforming to the following EN and IEC Standards: EN 61326-1 and IEC 61000H4-2 through 61000-4-6.
- ▶ Complies with NAMUR NE 21 Interference Immunity requirement (EMC).
- ▶ Analog output complies with NAMUR NE 43.
- ▶ Complies with all applicable European Union Directives (CE Logo marked on product).

WEIGHTS AND MEASURES CUSTODY TRANSFER OPTIONS -T AND -D

The -T option provides for Weights and Measures Custody Transfer per NIST Handbook 44. (An NTEP approved label is also applied to the enclosure.) This option incorporates the Tamperproof Sealing Option -S, and must be combined with CFS10 and CFS20 Flowtubes Custody Transfer Option -T.

The -D option provides for Weights and Measures Industry Canada Approvals. (A Weights and Measures Industry Canada approved label is also applied to the enclosure.) This option incorporates the Tamperproof Sealing Option -S below, and must be combined with CFS10 and CFS20 Flowtubes Weights and Measures Industry Canada Approvals Option -D.

TAMPERPROOF SEALING OPTION -S

Tamperproof Sealing of the enclosure and terminal box covers is provided by selecting Options -S.

LCD INDICATOR WITH LOCAL CONFIGURATOR

An LCD Indicator is used for local indication of flow measurement, total, and other menu-driven parameters. The indicator keypad, with four multifunction pushbuttons, also allows for flowmeter calibration, configuration, and self-test. The indicator scrolls and displays between multiple measurements.

Figure 1. LCD Indicator Face Plate

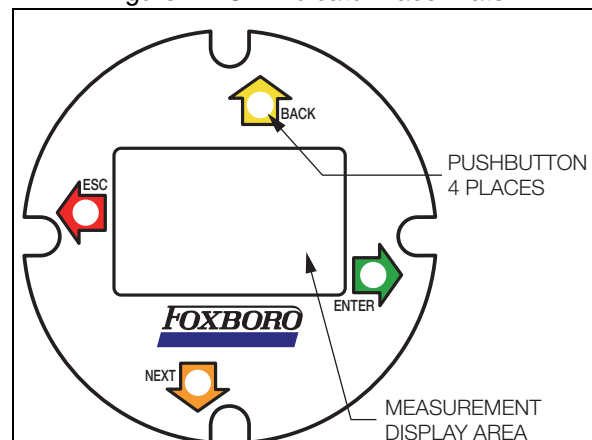

OPERATING, TRANSPORTATION, AND STORAGE CONDITIONS

Influence	Reference Operating Conditions	Normal Operating Condition Limits (a)	Transportation and Storage Limits (a)
Ambient Temperature (b)	23 ± 2°C (73 ± 3°F)	-40 and +60°C (c) (d) (-40 and +140°F)	-40 and +85°C (-40 and +185°F)
Relative Humidity	50 ± 10%	5 and 100% (e)	5 and 100% (e)
ac Supply Voltage and Frequency	120/240 V ac, ± 1% 50/60 Hz, ± 1%	120/240 V ac, +10/-15% 50/60 Hz, ± 5%	N/A
dc Supply Voltage	24 V dc, ± 5%	10 and 36 V dc	
Current Output: ▶ Supply Voltage ▶ Load	▶ 24 V dc ▶ 250 Ω (f)	▶ 24 V dc, ± 10% ▶ 250 Ω (f)	
Pulse Output: ▶ Supply Voltage ▶ Current	▶ 24 V dc ▶ 73 mA	▶ 24 V dc, ± 10% ▶ 80 mA	
Contact Input: ▶ Supply Voltage ▶ Current	▶ 24 V dc ▶ 12 mA	▶ 24 V dc, ± 10% ▶ 15 mA maximum	
Contact Output: ▶ Supply Voltage ▶ Current	▶ 24 V dc ▶ 100 mA	▶ 24 V dc, ± 10% ▶ 100 mA maximum	
RS485: ▶ Receive Input Range	± 5 V dc	± 5 V dc(g)	
Vibration	1 m/s ² (0.1 "g")	5 m/s ² (0.5 "g") from 5 to 500 Hz	

- (a) Values in the table apply when all transmitter covers have been properly installed and unused openings plugged according to installation instructions.
- (b) Including condensation.
- (c) If the temperature is between -20 and -40°C, the display may go blank, but the device is still operational.
- (d) Refer to the Electrical Safety Specifications section for a restriction in ambient temperature limits with certain electrical approvals and certifications.
- (e) Conditions producing sustained condensate are not allowed.
- (f) Minimum load required with HART Communicator or PC-based Configurator is 250 Ω. Operating below the 250 Ω requirement may cause communication problems.
- (g) The Operative Limits are -7 and +12 V dc.

SYSTEM PERFORMANCE SPECIFICATIONS

- 1 Performance specifications are stated at reference operating conditions (unless otherwise specified) using Invensys supplied cables with the output averaged for 1 minute.
- 2 All transmitters and tubes are interchangeable provided that the tube calibration parameters are loaded into the transmitter.
- 3 Performance specifications apply to the CFS10 or CFS20 tube and transmitter combined as a flowmeter system.
- 4 The performance specifications apply to all transmitter outputs with the following exception: The current output stage adds a maximum error of ±0.1% of the reading or less than 0.001% of meter capacity, whichever is greater.
- 5 Accuracy specifications are made for flows between 100% and 1% of flowtube Upper Range Limit (URL). The flowmeter system will operate below 1% of URL but no accuracy statements are made for this flow condition.

**Accuracy – Mass Flow Rate (Liquids)
(Includes Linearity, Hysteresis, and Repeatability)**

±0.10% + Zero Stability (see Table 1)

Accuracy in % of rate is therefore:

$$\text{Accuracy} = \pm 0.10\% + \left(\frac{\text{Zero Stability}}{\text{Mass Flow Rate}} \times 100 \right)\%$$

**Accuracy – Mass Flow Rate (Gases)
(Includes Linearity, Hysteresis, and Repeatability)**

±0.50% + Zero Stability (see Table 1)

Accuracy in % of rate is therefore:

$$\text{Accuracy} = \pm 0.50\% + \left(\frac{\text{Zero Stability}}{\text{Mass Flow Rate}} \times 100 \right)\%$$

Accuracy – Volumetric Flow Rate (Liquids Only)

Volumetric flow rate accuracy is the root sum of the squares (RSS) of Mass Flow Rate and Density accuracies. Mass Flow Rate and Density accuracies must be in the same units of measure.

Accuracy – Density (Liquids Only)

±0.0005 g/cm³ with both CFS10 and CFS20 mass flowtubes, provided by built-in density calibration function.

Table 1. Zero Stability (a)

Flowtube Model	Flowtube Size	Zero Stability	
		kg/min	lb/min
CFS10	3 mm (1/8 in)	0.00016	0.00035
	6 mm (1/4 in)	0.00045	0.001
	15 mm (1/2 in)	0.00204	0.0045
	20 mm (3/4 in)	0.00454	0.010
	25 mm (1 in)	0.00907	0.020
	40 mm (1 1/2 in)	0.0204	0.045
	50 mm (2 in)	0.0340	0.075
CFS20	40 mm (1 1/2 in)	0.0204	0.045
	80 mm (3 in)	0.0907	0.200

(a) In the accuracy equation, Zero Stability and Mass Flow Rate units must be the same.

Accuracy – Process Temperature

- ▶ ±1°C (±1.8°F) for process temperatures between -60 and +100°C (-76 and +212°F).
- ▶ ± 3°C (± 5.4°F) for process temperatures from -130 to -60°C (-202 to -76°F) and from 100 to 180°C (212 to 356°F).

Pressure Compensation

Although Foxboro flowtubes have thick walls, at elevated pressures, there is a small effect on accuracy due to pressure. CFT51 has a built in feature which allows pressure compensation for density and mass flow measurement, either by configuration or online pressure compensation.

The CFT51 supports both static and dynamic pressure compensation. Static compensation requires that the user enter a pressure value which will be stored in internal non-volatile memory and then applied during measurement calculations. Dynamic compensation requires that an external communication host provide real-time updates of internal pressure.

The default is to use a static pressure value for compensation unless an external live measurement is available. Only gauge pressure units are supported for the dynamic pressure input and the static configured value. Basic units are psig, barg, and kPag.

Ambient Temperature Effect

The effect is $\pm 0.0028\%$ of span per $^{\circ}\text{C}$ for any variation from Reference Operating Temperature within the Operating Limits.

Humidity Effect

No effect from 0 to 95% RH, noncondensing.

Supply Voltage Effect

A change in the supply voltage of +10 or -15% from reference voltage causes the output to change less than 0.1% of reading or less than 0.001% of meter capacity, whichever is greater.

Electromagnetic Compatibility (EMC)

The CFT51 Transmitter complies with International and European Union standards. Transmitter must be properly installed and housing earthed (grounded) per installation instructions. See Table 2 that follows.

Table 2. Electromagnetic Compatibility

Parameter	IEC and CISPR Standards	EN Standard
Radiated RFI Immunity	10 V/m per IEC 61000-4-3	10 V/m per EN 61000-4-3
Conducted RFI Immunity	10 V per IEC 61000-4-6	10 V per EN 61000-4-6
RFI Radiated and Conducted Emissions	Per CISPR 11, Class A	EN 55011 Class A
ESD Immunity	6 kV contact discharge per IEC 61000-4-2	6 kV contact discharge per EN 61000-4-2
Electrical Fast Transients/Burst Immunity	2 kV per IEC 61000-4-4	2 kV per EN 61000-4-4
Surge Immunity	2 kV per IEC 61000-4-5	2 kV per EN 61000-4-5
Power Dips and Interruptions	Per IEC 61000-4-11	Per EN 61000-4-11

FUNCTIONAL SPECIFICATIONS

Power Requirements⁽¹⁾

ac SUPPLY

Supply Voltage: 102 to 264 V ac, 120/240 V ac
Nominal

Supply Frequency: 47 to 63 Hz, 50/60 Hz
Nominal

Power: 18 VA maximum

dc SUPPLY

Supply Voltage: 10 to 36 V dc, 24 V dc nominal

Power: 15 W maximum

Operating Current: 1 A

Start-up Current: 3 A

Configurable Outputs

- ▶ Direct Mass Flow Rate
- ▶ Volumetric Flow Rate
- ▶ Totalized Mass Flow Rate
- ▶ Totalized Volumetric Flow Rate
- ▶ Process Fluid Density
- ▶ Temperature
- ▶ Bidirectional Flow
- ▶ Percent Solids/Concentration
- ▶ Net Flow, Component A, Component B
- ▶ Brix and Baumé Scales

Digital Communications

The digital communication interface is selectable for HART or Modbus via the pushbuttons on the LCD indicator keypad. The transmitter is configurable using the keypad. If a blind unit (no LCD indicator) is selected, then the transmitter will be factory configured for HART or Modbus, as applicable, and digital communication will be via the HART Communicator or PC-based Configurator.

Upper Range Value (URV) Rangeability

100:1; minimum URV = 1% of meter Upper Range Limit (URL)

Response Time (Undamped)

Transmitter response time varies with the output selected, and is defined as a 90% recovery time to an 80% input step per ANSI/ISA-S51.1 with zero electronic damping. See the table below.

Output Selected	Response Time
Digital Output	35 ms
Analog Output	35 ms + 350 ms
Pulse Output	35 ms

Cold Power-Up/Reset Delay

Less than 2 second delay for outputs to begin to move toward measured value.

Bi-Directional Flow

All necessary functionality is available to provide all flow measurements in the forward or reverse direction. Quadrature pulse output has the ability to indicate flow direction.

Totalization

The transmitter has nonvolatile memory for the four on-board totalizers each of which support:

- ▶ Forward Total
- ▶ Reverse Total
- ▶ Bi-directional Total

Each totalizer can be configured to have either of two levels of password protection.

Diagnostics/Alarms

Diagnostic and alarm functions are provided. The diagnostics and alarms can be configured to be visual via the local LCD indicator, as a signal output via the 4 to 20 mA and/or pulse outputs, as a contact output, or read via the digital communications interface.

(1) Also refer to OPERATING CONDITIONS table.

Transmitter I/O

The transmitters nondigital communications I/O are user-configurable. These inputs/outputs are isolated from each other and must be externally powered. The following nondigital I/O types are available:

- ▶ Analog Current Outputs
- ▶ Analog Current Output Alarm
- ▶ Frequency or Scaled Pulse Outputs
- ▶ Quadrature Pulse Output
- ▶ Contact Output - Configurable
- ▶ Contact Input - Configurable

Analog Current Outputs

There are three independent, 4 to 20 mA outputs. HART communication is provided on the first current output. All transmitter I/Os must be externally powered. Specifications are:

- Output Load: 0 to 680 Ω
- Supply Voltage: 24 V dc ±10%
- Current: 22 mA maximum, 3.9 mA minimum
- Output Ripple: Less than 0.05% of span

Analog Current Output Alarm (High/Low)

This output alarm feature allows communicating a diagnostic error to the current loop receiver. When the error is flagged, the current output can go Upscale, go Downscale, or remain at last value.

Specifications are as follows:

- Supply Voltage: 24 V dc ±10%
- Current: 4 to 20 mA nominal
- Underrange/Overrange: 3.8 to 20.5 mA (measurement still valid)
- Alarm Range ≤ 3.6 or ≥ 21.0 mA

Selectable Pulse Outputs

There are two independent pulse outputs. Each output can be configured as a frequency output or as a frequency or scaled pulse output signal. See below.

FREQUENCY OUTPUT

This output configuration can be assigned to mass or volume flow rate, density, temperature, or percent solids measurements. The frequency can be configured to as high as 10 kHz.

Frequency Output specifications are as follows:

- ▶ Selectable Frequency: 0 to 10 kHz
- ▶ Frequency Duty Cycle: 50% nominal
- ▶ Supply Voltage: 24 V dc ±10%
- ▶ Load Current: 80 mA maximum

SCALED PULSE OUTPUT

This output drives low speed totalizers. A pulse is sent for every user-configured mass total that has accumulated. Specifications are as follows:

- Supply Voltage: 24 V dc ±10%
- Load Current: 80 mA maximum
- Pulse Width: See table below

Maximum Frequency: See table below

Configurable Speed	Pulse Width	Maximum Frequency
SLOW	50 ms	10 Hz
FAST	5 ms	100 Hz

NOTE

A 256 pulse buffer stores pulses in case of temporary overrange conditions.

Quadrature Pulse Output

A quadrature pulse output uses two pulsed outputs that are ±90° out of phase with one another. The polarity (±) indicates the flow direction. The quadrature output can be configured to output any reading that a pulsed output can.

PHYSICAL SPECIFICATIONS**Contact Output - Configurable**

A contact output is provided and configurable as:

- ▶ Hi-Lo Level Alarm Indicator
- ▶ Diagnostic Alarm Indicator
- ▶ Alarm/Diagnostic Indicator

Specifications are as follows:

Type: Relay, 1 Form A (Isolated)
 Supply Voltage: 24 V dc $\pm 10\%$
 Current Rating: 100 mA maximum

Contact Input - Configurable

A contact input is externally powered and configurable as:

- ▶ A 4 to 20 mA Output Lock
- ▶ An External Totalizer Reset
- ▶ Initiate a Flow Zero
- ▶ Select a Zero Flow Value

Specifications are as follows:

Type: Requires current linking device such as contact closure or transistor switch between terminal block connections provided.
 Supply Voltage: 24 V dc $\pm 10\%$
 Current Rating: 15 mA maximum

PHYSICAL SPECIFICATIONS**Transmitter Enclosure**

The transmitter is comprised of a cast aluminum alloy material with three separate compartments. The main compartment houses the transmitter electronics (PWAs) and LCD indicator. A second compartment houses terminals to accommodate power and I/O cables (field wiring), and the third compartment houses terminals for sensor input and PE (physical earth) wiring. A gasketed cover is provided for each compartment. See DIMENSIONS-NOMINAL section.

The enclosure has a blue polyester paint finish, and optionally a blue epoxy powder finish. The compartment covers have a gray epoxy powder finish.

The 3-compartment enclosure and electronics design allows for use in Division 1 intrinsically safe, explosionproof, and flameproof installations. Tamperproof sealing of the enclosure covers are provided when selecting Tamperproof Sealing Option -S, Weights and Measures Custody Transfer Option -T, or Weights and Measures Industry Canada Approvals Option -D.

When selecting Option -T, an NTEP approved label is applied to the enclosure. When selecting Option -T, you must also select the CFS10 or CFS20 Flowtubes Custody Transfer Option -T. Similarly, selecting Option -D requires that you also select the CFS10 or CFS20 Weights and Measures Industry Canada Approvals Option -D.

Transmitter Mounting

Four 0.437-20 UNS threaded holes are provided on the surface of the enclosure on which a carbon steel mounting bracket or optional stainless steel mounting bracket can be attached. The other surface of the bracket allows for mounting to a surface, or to a nominal DN50 (2 inch) vertical or horizontal pipe, or an optional mounting bracket for a DN80 (3 inch) pipe.

Environmental Protection

Printed wiring assemblies (PWAs) are conformally coated for moisture and dust protection. The enclosure has the dusttight and weatherproof rating of IP66/67 as defined by IEC 60529, and provides the environmental and corrosion resistant protection rating of NEMA 4X.

Electrical Connections

Sensor Input And PE Connections

Two 1/2 NPT threaded holes are provided in the sensor input and PE connections compartment. One hole is for sensor wires, and the other for PE wires.

Field Wiring Connections

Two M20 or 1/2 NPT threaded holes are provided in the field wiring compartment. One hole is for power wires, and the other for I/O wires.

Earth (Ground) Connections

In addition to internal ground connections, an external ground terminal is provided on the front surface of the enclosure.

Transmitter to Flowtube Wiring

An interconnecting cable can be selected in lengths to 300 meters or to 1000 feet (see Model Code). An IPVC insulated cable is offered with a temperature range from -20 to +80°C (-4 to +176°F). An FEP insulated cable is offered with a temperature range from -40 to +85°C (-40 to +185°C).

Dual Seal Certification

CFS10 and CFS20 flowtubes are dual seal approved to meet ANSI/ISA 12.27.01 requirements when connected to a CFT51 transmitter. Refer to PSS 1-2B1 A for CFS10/CFS20 specifications.

LCD Indicator with Keypad

Four softkeys provide full configuration capability. The electronics compartment cover must be removed to access the keypad. See Figure 1 for the indicator faceplate configuration.

Approximate Mass

9.4 kg (20.7 lb)

Dimensions

See DIMENSIONS-NOMINAL section.

ELECTRICAL SAFETY SPECIFICATIONS

These transmitters have been designed to meet the electrical safety specifications listed in the table below. Contact Invensys (see back page) for the status of agency approvals or certifications.

Types of Protection and Area Classification	Application Conditions	Electrical Safety Design Code
ATEX, II 2/1 G Exd [ia] IIC Gb (Ga)	Flameproof enclosure with Intrinsic safe sensor outputs. Temperature Class T6. Ta = -40°C to +60°C.	ADA
ATEX, II 2/3 G Exd [ic] IIC Gb (Gc)	Flameproof enclosure with Energy Limited or intrinsic safe zone 2 sensor outputs. Temperature Class T6. Ta = Ta -40°C to +60°C.	ADN
ATEX, II 3/1 G Ex nA [ia] IIC Gc (Ga)	Non-sparking enclosure with Intrinsic safe sensor Temperature Class T4. Ta = -40°C to +60°C.	ANA
ATEX, II 3 G Ex nA IIC Gc	Non-sparking Temperature Class T4. Ta = -40°C to +60°C	ANN
CSA/CSAus XP Class I, Division 1, Groups A, B, C, and D; Class II, Division 1, Groups E, F, and G; Class III, Division 1; AIS Class I, Division 1, Groups A, B, C, and D; Ex d [ia] IIC	Explosionproof and Flameproof enclosure with intrinsically safe outputs Temperature Class T6. Ta = -40°C to 60°C Temperature Class T4. Ta = -40°C to 60°C	CDA
CSA/CSAus XP Class I, Division 1, Groups A, B, C, and D; Class II, Division 1, Groups E, F, and G; Class III, Division 1; ANI Class I, Division 2, Groups A, B, C, and D; AEx d [nL] IIC	Explosionproof and Flameproof enclosure with Non-Incendive outputs Temperature Class T6. Ta = -40°C to 60°C Temperature Class T4. Ta = -40°C to 60°C	CDN
CSA/CSAus NI Class I, Division 2, Groups A, B, C, and D; also intrinsically safe for ASI Class I, Division 1, Groups A, B, C, and D; AEx nA [ia] IIC	Non-incendive enclosure with intrinsically safe outputs Temperature Class T4. Ta = -40°C to 60°C	CNA
CSA/CSAus NI Class I, Division 2, Groups A, B, C, and D; also nonincendive for ASI Class I, Division 1, Groups A, B, C, and D; Ex nA IIC	Non-incendive and Non-sparking Temperature Class T4. Ta = -40°C to 60°C	CNN
FM XP Class I, Division 1, Groups A, B, C, and D; Class II, Division 1, Groups E, F, and G; Class III, Division 1 AIS Class I, Division 1, Groups A, B, C, and D. AEx d [ia] IIC	Explosionproof and Flameproof enclosure with intrinsically safe outputs Temperature Class T6. Ta = -40°C to 60°C Temperature Class T4. Ta = -40°C to 60°C	FDA
FM XP Class I, Division 1, Groups A, B, C, and D; Class II, Division 1, Groups E, F, and G; Class III, Division 1; ANI Class I, Division 2, Groups A, B, C, and D. AEx d [nC] IIC	Explosionproof and Flameproof enclosure with Non-Incendive outputs Temperature Class T6. Ta = -40°C to 60°C Temperature Class T4. Ta = -40°C to 60°C	FDN
FM NI Class I, Division 2, Groups A, B, C, and D; ASI Class I, Division 1, Groups A, B, C, and D AEx nA [ia] IIC	Non-incendive enclosure with intrinsically safe outputs Temperature Class T4. Ta = -40°C to 60°C	FNA
FM NI Class I, Division 2, Groups A, B, C, and D; ASI Class I, Division 1, Groups A, B, C, and D AEx nA IIC	Non-Incendive Temperature Class T4. Ta = -40°C to 60°C	FNN

Types of Protection and Area Classification	Application Conditions	Electrical Safety Design Code
IECEX, II 2/1 G, Ex d [ia] IIC; Gb (Ga)	Flameproof enclosure with Intrinsic safe sensor outputs. Temperature Class T6 Ta = -40°C to 60°C	EDA
IECEX, II 2/3 G Ex d [ic] IIC; II 2/3 G Ex d [nL] IIC; Gb (Gc)	Flameproof enclosure with Energy Limited or intrinsic safe zone 2 sensor outputs Temperature Class T6. Ta = -40°C to 60°C	EDN
IECEX, II 2/1 G, Ex d [ia], IIC. Gb (Ga)	Non-sparking enclosure with Intrinsic safe sensor. Temperature Class T6 Ta = -40°C to 60°C	ENA
IECEX, II 3 G, Ex nA, IIC. Gc	Non-sparking Temperature Class T4. Ta = -40°C to 60°C	ENN
NEPSI, II 2/1 G, Ex d [ia] IIC	Flameproof enclosure with Intrinsic safe sensor outputs Temperature Class T6. Ta = -40°C to 60°C	NDA
NEPSI, II 2/3 G, Ex d [ic] II and II 2/3 G, Ex d [nL] IIC	Flameproof enclosure with Energy Limited or intrinsic safe zone 2 sensor outputs Temperature Class T6. Ta = -40°C to 60°C	NDN
NEPSI, II 2/1 G, Ex d [ia] IIC. Gb (Ga)	Non-sparking enclosure with Intrinsic safe sensor Temperature Class T6. Ta = -40°C to 60°C	NNA
NEPSI, II 3 G, Ex nA IIC	Non-sparking Temperature Class T4. Ta = -40°C to 60°C	NNN
No Certifications	Not Applicable	ZZZ

MODEL CODE

MODEL CODE

<u>Description</u>	<u>Model</u>
Digital Coriolis Mass Flow Transmitter	CFT51
<u>Communication Interface (a)</u>	
HART Communication Protocol	-T
Modbus Communication Protocol	-M
<u>Mass Flowtube Sensor</u>	
Models CFS10 and CFS20 Mass Flowtubes	B
<u>Transmitter Mounting</u>	
Remote Mounted Transmitter	1
<u>Language</u>	
English	E
<u>Supply Voltage</u>	
120/240 V ac, 50/60 Hz, Externally Powered I/O	A
10 to 36 V dc, Externally Powered I/O	B
<u>LCD Indicator with Keypad</u>	
None; this is a Blind Unit	A
Integral LCD Indicator with Keypad	B
<u>Housing Field Cable Entries</u>	
1/2 NPT Connection (Two places)	A
M20 Connection (Two places)	B
<u>Interconnecting Cable Material</u>	
No Cable	N
IPVC Insulated Cable; Temperature Range from -20 to +80°C (-4 to +176°F)	P
FEP Insulated Cable; Temperature Range from -40 to +85°C (-40 to +185°F)	F
<u>Interconnecting Cable Length</u>	
No Cable	N
20 foot cable/6 meter cable	G
50 foot cable/15 meter cable	P
100 foot cable/31 meter cable	H
200 foot cable/61 meter cable	J
500 foot cable/152 meter cable	K
750 foot cable/229 meter cable	L
1000 foot cable/305 meter cable	M

MODEL CODE (CONTINUED)

<u>Electrical Safety (Also see Electrical Safety Specifications section)</u>	
ATEX flameproof with intrinsically safe flowtube connections	ADA
ATEX flameproof with energy limited flowtube connections	ADN
ATEX nonsparking with intrinsically safe flowtube connections	ANA
ATEX nonsparking with energy limited flowtube connections	ANN
CSA/CSAus explosionproof with intrinsically safe flowtube connections	CDA
CSA/CSAus explosionproof with nonincendive flowtube connections	CDN
CSA/CSAus nonincendive and energy limited with intrinsically safe flowtube connections	CNA
CSA/CSAus nonincendive with nonincendive flowtube connections	CNN
FM explosionproof with intrinsically safe flowtube connections	FDA
FM explosionproof with nonincendive flowtube connections	FDN
FM nonincendive with intrinsically safe flowtube connections	FNA
FM nonincendive with nonincendive safe flowtube connections	FNN
IECEX flameproof with intrinsically safe flowtube connections	EDA
IECEX flameproof with energy limited flowtube connections	EDN
IECEX nonsparking with intrinsically safe flowtube connections	ENA
IECEX nonsparking with energy limited flowtube connections	ENN
NEPSI flameproof with intrinsically safe flowtube connections (b)	NDA
NEPSI flameproof with energy limited flowtube connections (b)	NDN
NEPSI nonsparking with intrinsically safe flowtube connections (b)	NNA
NEPSI nonsparking with energy limited flowtube connections (b)	NNN
No Certifications	ZZZ
<u>Tamperproof Sealing, Custody Transfer, and Weights and Measures Industry Canada Options</u>	
Tamperproof Sealing for Housing and Terminal Block Covers	-S
Weights and Measures Custody Transfer (NTEP) (c)	-T
Weights and Measures Industry Canada Approvals (d)	-D
<u>Paint Options</u>	
Epoxy Paint (e)	-E
<u>Mounting Bracket Material and Pipe Size</u>	
Stainless Steel	-F
Carbon Steel, 3-inch pipe	-G
Stainless Steel, 3-inch pipe	-H

- (a) Factory default setting. Transmitters with display and keypad may be changed in the field.
- (b) These transmitters have been designed to meet the electrical safety specifications listed in the table above. Contact Invensys (see back page) for the status of agency approvals or certifications.
- (c) When used with the Models CFS10 and CFS20 Style B Flowtubes, the flowtubes must also have Option -T (NTEP). Also, Option -T is only available with LCD Indicator with Keypad Code B.
- (d) When used with the Models CFS10 and CFS20 Style B Flowtubes, the flowtubes must also have Option -D (Weights and Measures Industry Canada Approvals).
- (e) Epoxy paint finish option applies to the enclosure body; the enclosure covers use an epoxy paint finish as standard.

DIMENSIONS – NOMINAL

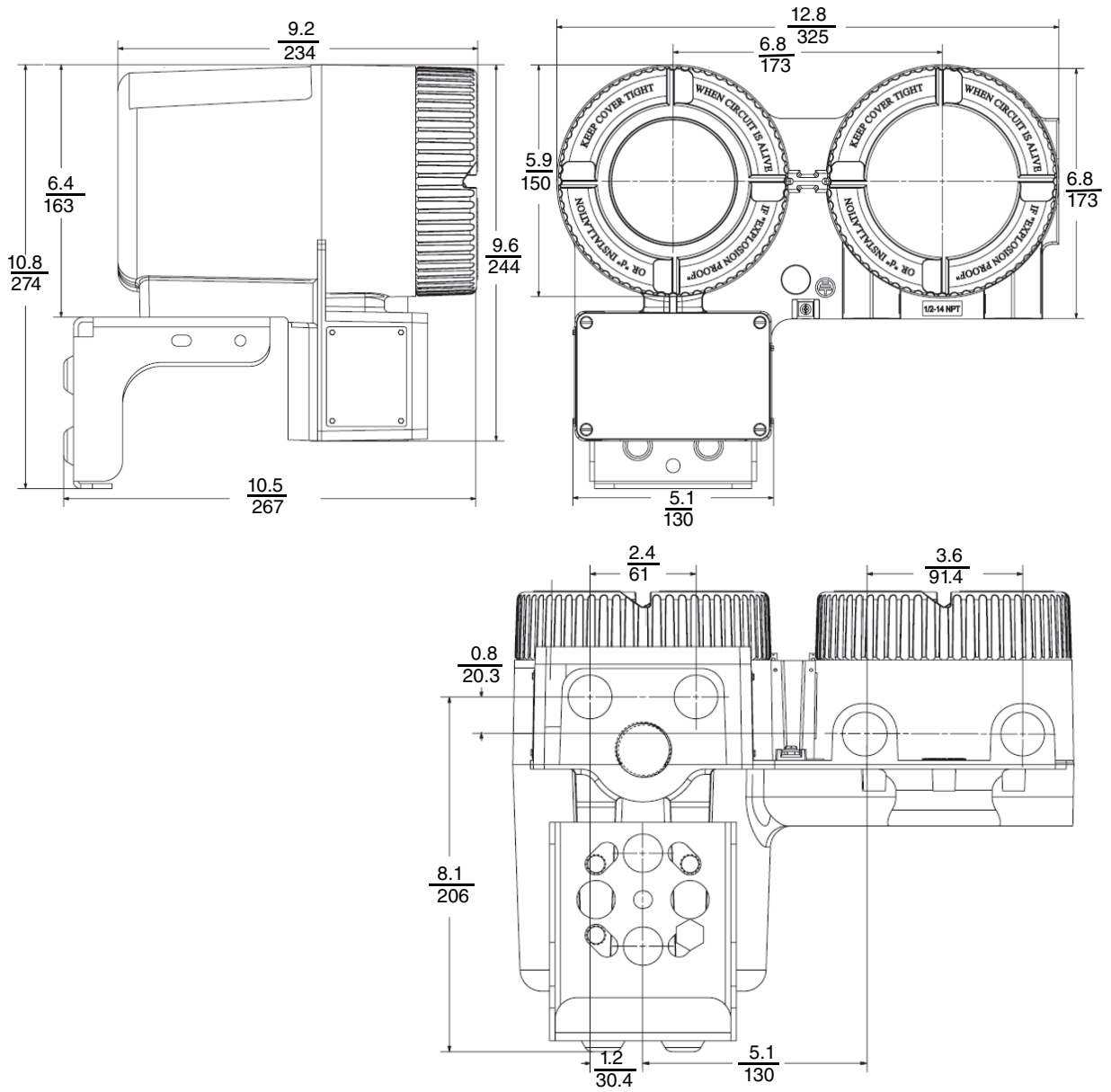

ORDERING INSTRUCTIONS

1. Model Number.
2. Process data and gas or liquid applications; visit FlowExpertPro.com sizing program.
3. If interconnecting cable is required, refer to PSS 1-2B1 A (CFS10 and CFS20 Mass Flowtubes) for ordering instructions.
4. If ordering a replacement for a CFT51 Mass Flow Transmitter, specify the meter serial number.
5. Flowtube Model used.
6. User Tag Data.

REFERENCE DOCUMENTS

Description	PSS Number
CFS10 Mass Flowtube; 3 to 50 mm (1/8 to 2 in) Sizes	PSS 1-2B1 A
CFS20 Mass Flowtube; 40 and 80 mm (1.5 and 3 in) Sizes	PSS 1-2B1 A

OTHER M&I PRODUCTS

Invensys provides a broad range of measurement and instrument products, including solutions for pressure, flow, analytical, positioners, temperature, controlling and recording. For a listing of these offerings, visit our web site at:

www.invensys.com

Invensys
10900 Equity Drive
Houston, TX 77041
United States of America
<http://www.invensys.com>

Global Customer Support
Inside U.S.: 1-866-746-6477
Outside U.S.: 1-508-549-2424 or contact
your local Invensys representative.
Website: <http://support.ips.invensys.com>

Invensys, Foxboro, and I/A Series are trademarks of Invensys plc, its subsidiaries, and affiliates. All other brand names may be trademarks of their respective owners.

Copyright 2011-2013 Invensys Systems, Inc.
All rights reserved